

Table of Contents

WAC 296-155-24501, Scope and Application
WAC 296-155-24503, Definitions
WAC 296-155-24505, General Requirements
WAC 296-155-24507, Fall Protection Required Regardless of Height
WAC 296-155-24509, Fall Protection Required at 4 Feet
WAC 296-155-24511, Fall Protection Required at 10 Feet
WAC 296-155-24513, Fall Arrest Specifications
WAC 296-155-24515, Fall Restraint Specifications
WAC 296-155-24517, Positioning Device System Specifications
WAC 296-155-24519, Other Specifications
WAC 296-155-24521, Training
WAC 296-155-24523, Appendix A: Determining roof widths. Non-mandatory guidelines for complying with WAC 296-155-24515(5).
WAC 296-155-24524, Appendix B: Calculating fall clearance distance using a shock-absorbing lanyard and d-ring anchorage connector. Non-mandatory guidelines for complying with WAC 296-155-24513(1)(d).

WAC 296-155-24501, Scope and Application.

Chapter 296-155 WAC, Part C-1 sets forth requirements for employers to provide and enforce the use of fall protection for employees performing activities covered under chapter 296-155 WAC.

Note: Additional standards requiring fall protection include:

- Chapter 296-869 WAC - Vehicle Mounted Aerial Platforms, and Boom Supported Elevating Work Platforms
- Chapter 296-874 WAC - Scaffolds
- Chapter 296-876 WAC - Ladders
- Chapter 296-155 WAC - Part J: Stairways
Part L: Crane and Derrick Supported Work Platforms
Part M: Pile Driving
Part O: Placing and Removal of Forms, and Vertical Slip Forms
Part P: Steel Erection Temporary Floors

WAC 296-155-24503, Definitions.

(1) **Affected area** means the distance away from the edge of an excavation equal to the depth of the excavation up to a maximum distance of 15 feet. For example, an excavation 10 feet deep has an affected area extending 10 feet from the edge of any side of the excavation.

(2) **Anchorage** means a secure point of attachment for lifelines, lanyards, or deceleration devices that are capable of withstanding the forces specified in chapter 296-155 WAC, Part C-1.

(3) **Catch platform** means a type of fall arrest system that consists of a platform installed within 4 vertical feet of the fall hazard; is at least 45 inches wide and is equipped with a standard guardrail system on all exposed sides.

(4) **Catenary line** - see horizontal lifeline.

(5) **Competent person** means an individual knowledgeable of fall protection equipment, including the manufacturers recommendations and instructions for the proper use, inspection, and maintenance; and who is capable of identifying existing and potential fall hazards; and who has the authority to take prompt corrective action to eliminate those hazards; and who is knowledgeable of the rules in chapter 296-155 WAC, Part C-1 regarding the installation, use, inspection, and maintenance of fall protection equipment and systems.

(6) **Connector** means a device used to connect parts of the personal fall arrest system and positioning device systems together. It may be an independent component of the system, such as a carabiner, or it may be an integral component of part of the system (such as a buckle or D-ring sewn into a harness, or a snap hook spliced or sewn to a lanyard or self-retracting lanyard).

WAC 296-155-24503 (Cont.)

- (7) **Deceleration device** means any mechanism, such as a rope grab, ripstitch lanyard, specifically woven lanyard, tearing or deforming lanyards, automatic self-retracting lifelines/lanyards, etc., which serves to dissipate a substantial amount of energy during a fall arrest, or otherwise limit the energy imposed on an employee during fall arrest.
- (8) **Deceleration distance** means the additional vertical distance a falling employee travels, excluding lifeline elongation and free fall distance, before stopping, from the point at which the deceleration device begins to operate. It is measured as the distance between the location of an employee's full body harness attachment point at the moment of activation (at the onset of fall arrest forces) of the deceleration device during a fall, and the location of that attachment point after the employee comes to a full stop.
- (9) **Drop line** means a vertical lifeline secured to an upper anchorage for the purpose of attaching a lanyard or device.
- (10) **Equivalent** means alternative designs, materials or methods to protect against a hazard which the employer can demonstrate will provide an equal or greater degree of safety for employees than the methods, materials or designs specified in the standard.
- (11) **Fall arrest system** means a fall protection system that will arrest a fall from elevation. Fall arrest systems include personal fall arrest systems that are worn by the user, catch platforms, and safety nets.
- (12) **Fall protection work plan** means a written planning document in which the employer identifies all areas on the job site where a fall hazard of 10 feet or more exists. The plan describes the method or methods of fall protection to be used to protect employees, and includes the procedures governing the installation, use, inspection, and removal of the fall protection method or methods which are selected by the employer. See WAC 296-155-24511(2).
- (13) **Fall restraint system** means a system in which all necessary components function together to restrain/prevent an employee from falling to a lower level. Types of fall restraint systems include standard guardrail systems, personal fall restraint systems, warning line systems, or a warning line system and safety monitor.
- (14) **Fall distance** means the actual distance from the workers support to the level where a fall would stop.
- (15) **Floor hole** means an opening measuring less than 12 inches but more than 1 inch in its least dimension in any floor, roof, or platform through which materials but not persons may fall, such as a belt hole, pipe opening, or slot opening.
- (16) **Floor opening** means an opening measuring 12 inches or more in its least dimension in any floor, roof, or platform, through which persons may fall.
- (17) **Free fall** means the act of falling before a personal fall arrest system begins to apply force to arrest the fall.
- (18) **Free fall distance** means the vertical displacement of the fall arrest attachment point on the employee's full body harness between onset of the fall and just before the system begins to apply force to arrest the fall. This distance excludes deceleration distance, and lifeline/lanyard elongation, but includes any deceleration device slide distance or self-retracting lifeline/lanyard extension before they operate and fall arrest forces occur.
- (19) **Full body harness** means a configuration of connected straps that meets the requirements specified in ANSI Z359.1-2007, that may be adjustable to distribute a fall arresting force over at least the thighs, shoulders and pelvis, with provisions for attaching a lanyard, lifeline, or deceleration devices.
- (20) **Full body harness system** means a full body harness and lanyard which is either attached to an anchorage meeting the requirements of chapter 296-155 WAC, Part C-1; or it is attached to a horizontal or vertical lifeline which is properly secured to an anchorage(s) capable of withstanding the forces specified in chapter 296-155 WAC, Part C-1.
- (21) **Handrail** means a rail used to provide employees with a handhold for support.
- (22) **Hardware** means snap hooks, D-rings, bucklers, carabiners, adjusters, O-rings, that are used to attach the components of a fall protection system together.

WAC 296-155-24503 (Cont.)

(23) **Hazardous slope** means a slope where normal footing cannot be maintained without the use of devices due to the pitch of the surface, weather conditions, or surface material.

(24) **Horizontal lifeline** means a rail, rope, wire, or synthetic cable that is installed in a horizontal plane between two anchorages and used for attachment of a workers lanyard or lifeline device while moving horizontally; used to control dangerous pendulum like swing falls.

(25) **Lanyard** means a flexible line of webbing, rope, or cable used to secure a positioning harness or full body harness to a lifeline or an anchorage point usually 2, 4, or 6 feet long.

(26) **Leading edge** means the advancing edge of a floor, roof, or formwork which changes location as additional floor, roof, or formwork sections are placed, formed, or constructed.

(27) **Lifeline** means a vertical line from a fixed anchorage or between two horizontal anchorages, independent of walking or working surfaces, to which a lanyard or device is secured. Lifeline as referred to in this text is one which is part of a fall protection system used as back-up safety for an elevated worker or as a restraint for workers on a flat or sloped surface.

(28) **Locking snap hook** means a connecting snap hook that requires two separate actions to open the gate; one to deactivate the gatekeeper and a second to depress and open the gate which automatically closes when released; used to minimize roll out or accidental disengagement.

(29) **Low-pitched roof** means a roof having a slope less than or equal to 4:12.

(30) **Mechanical equipment** means all motor or human propelled wheeled equipment except for wheelbarrows, mopcars, robotic thermoplastic welders and robotic crimpers.

(31) **Personal fall arrest system** means a fall arrest system that is worn by the employee to arrest the employee in a fall from elevation. It consists of an anchor point, connectors, a full body harness, and may include a lanyard, deceleration device, lifeline, or suitable combinations of these.

(32) **Personal fall restraint system** means a fall restraint system that is worn by the employee to keep the employee from reaching a fall point, such as the edge of a roof or elevated work surface. It consists of an anchor point, hardware assemblies, a full body harness and may include a lanyard, restraint lines, or suitable combinations of these.

(33) **Platform** means a work surface elevated above the surrounding floor or ground.

(34) **Positioning device system** means a full body harness or positioning harness that is worn by an employee, and is rigged to allow an employee to be supported on an elevated vertical or inclined surface, such as a wall, pole, or column and work with both hands free from the body support.

(35) **Positioning harness** means a body support that meets the requirements specified in ANSI Z359.3-2007 that encircles and closes around the waist and legs with attachment elements appropriate for positioning work.

(36) **Qualified person** means one who, by possession of a recognized degree, certificate, or professional standing, or who by extensive knowledge, training, and experience, has successfully demonstrated his/her ability to solve or resolve problems related to the subject matter, the work, or the project.

(37) **Restraint line** means a line from a fixed anchorage or between two anchorages to which an employee is secured in such a way as to prevent the worker from falling to a lower level.

(38) **Roof** means the exterior surface on the top of a building. This does not include floors or formwork; which, because a building has not been completed, temporarily become the top surface of a building.

(39) **Roofing work** means the hoisting, storage, application, and removal of roofing materials and equipment, including related insulation, sheet metal, and vapor barrier work, but not including the construction of the roof deck.

WAC 296-155-24503 (Cont.)

- (40) **Rope grab** means a fall arrester that is designed to move up or down a lifeline suspended from a fixed overhead or horizontal anchorage point, or lifeline, to which the full body harness is attached. In the event of a fall, the rope grab locks onto the lifeline rope through compression to arrest the fall. The use of a rope grab device is restricted for all restraint applications; see WAC 296-155-24515(1)(f).
- (41) **Runway** means a passageway for persons, elevated above the surrounding floor or ground level, such as a footwalk along shafting or a walkway between buildings.
- (42) **Safety line** - see lifeline.
- (43) **Safety-monitoring system** means a type of fall restraint system in which a competent person whose only job responsibility is to recognize and warn employees of their proximity to fall hazards when working between the warning line and the unprotected sides and edges, including the leading edge of a low pitch roof or other walking/working surface.
- (44) **Safety net system** means a type of fall arrest system, as described in WAC 296-155-24513(2).
- (45) **Safety watch system** means a fall protection system as described in WAC 296-155-24515(6), in which a competent person monitors one worker who is engaged in repair work or servicing equipment on low pitch roofs only.
- (46) **Self-rescue device** means a piece of equipment designed to allow a person, who is suspended in a personal fall arrest system, to independently rescue themselves after the fall by moving the device up or down until they reach a surface and are no longer suspended.
- (47) **Self retracting lifeline** means a deceleration device which contains a wound line which may be slowly extracted from, or retracted onto, the device under slight tension during normal employee movement, and which after onset of a fall, automatically locks and arrests the fall.
- (48) **Shock absorbing lanyard** means a flexible line of webbing, cable, or rope used to secure full body harness to a lifeline or anchorage point that has an integral shock absorber.
- (49) **Snap hook** -- see "Locking snap hook."
- (50) **Standard guardrail system** means a type of fall restraint system that is a vertical barrier consisting of a top rail and mid rail, and toe board when used as falling object protection for persons who may work or pass below), that is erected along all open sides or edges of a walking/working surface, a floor opening, a floor hole, wall opening, ramp, platform, or runway.
- (51) **Standard strength and construction** means any construction of railings, covers, or other guards that meets the requirements of this part.
- (52) **Static line** - see horizontal lifeline.
- (53) **Steep-pitched roof** means a roof having a slope greater than 4:12.
- (54) **Toe board** means a vertical barrier at floor level erected along all open sides or edges of a floor opening, platform, runway, ramp, or other walking working surface to prevent materials, tools, or debris from falling onto persons passing through or working in the area below.
- (55) **Unprotected sides and edges** means any open side or edge of a floor, roof, balcony/deck, platform, ramp, runway, or walking working surface where there is no standard guardrail system, or parapet wall of solid strength and construction that is at least 39 inches in vertical height.
- (56) **Walking/working surface** means any area including but not limited to floors, a roof surface, bridge, the ground, and any other surfaces whose dimensions are 45 inches or more in all directions, through which workers can pass or conduct work.

WAC 296-155-24503 (Cont.)

(57) **Wall opening** means an opening at least 30 inches high and 18 inches wide, in any wall or partition, through which persons may fall, such as an opening for a window, a yard arm doorway or chute opening.

(58) **Warning line system** means a barrier erected on a walking and working surface or a low pitch roof (4:12 or less), to warn employees that they are approaching an unprotected fall hazard(s).

WAC 296-155-24505, General Requirements.

(1) The employer shall ensure that all surfaces on which employees will be working or walking on are structurally sound and will support them safely prior to allowing employees to work or walk on them.

(2) Inspection criteria.

(a) All Components (including hardware, lanyards, and positioning harnesses or full body harnesses depending on which system is used), of personal fall arrest systems, personal fall restraint systems and positioning device systems shall be inspected prior to each use according to manufacturer's specifications for mildew, wear, damage, and other deterioration. Defective components shall be removed from service if their function or strength has been adversely affected.

(b) Safety nets shall be inspected at least once a week according to manufacturer's specifications for wear, damage, and other deterioration. Safety nets shall also be inspected after any occurrence which could affect the integrity of the safety net system. Defective components shall be removed from service. Defective nets shall not be used.

(3) Personal fall arrest systems, personal fall restraint system, positioning device systems, and their components shall be used only for employee protection and not to hoist materials.

(4) Exemptions. Employees are exempt from sections WAC 296-155-24509 and WAC 296-155-24511 only under the following conditions:

(a) During initial installation of the fall protection anchor (prior to engaging in any work activity), or the disassembly of the fall protection anchor after the work has been completed.

(b) An employee directly involved with inspecting or estimating roof-level conditions only on low-pitched roofs prior to the actual start of construction work or after all construction work has been completed.

Examples of activities the department recognizes as inspecting or estimating include:

- Measuring a roof to determine the amount of materials needed for a project
- Inspecting the roof for damage without removing equipment or components
- Assessing the roof to determine what method of fall protection will be provided to employees

Examples the department does not recognize as inspecting or estimating under this exemption include:

- Delivering, staging or storing materials on a roof
- Persons estimating or inspecting on roofs that would be considered a "Hazardous Slope," by definition.

WAC 296-155-24505 (Cont.)

TYPES OF FALL PROTECTION SYSTEMS

Fall Arrest Stopped after the fall with a 6 ft. maximum free fall distance WAC 296-155-24513	
•Personal fall arrest	WAC 296-155-24513(1)
•Safety nets	WAC 296-155-24513(2)
•Catch platforms	WAC 296-155-24513(3)
Fall Restraint Restrained from falling WAC 296-155-24515	
•Personal fall restraint	WAC 296-155-24515(1)
•Guardrails	WAC 296-155-24515(2)
•Covers	WAC 296-155-24515(3)
•Warning line system	WAC 296-155-24515(4)
•Safety monitor	WAC 296-155-24515(5)
•Safety watch	WAC 296-155-24515(6)
Positioning Device WAC 296-155-24517	
•Positioning harness/full body harness with a 2 ft. maximum free fall distance.	
•Vertical walls, columns, poles, hazardous slopes, and steep pitches.	

Examples of what personal fall arrest, personal fall restraint and positioning device systems look like:

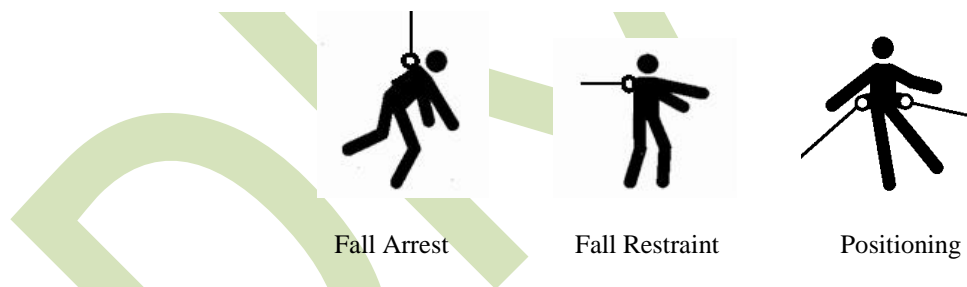

WAC 296-155-24507, Fall Protection Required Regardless of Height.

(1) Regardless of height, open sided floors, walkways, platforms, or runways above or adjacent to dangerous equipment, such as rock crushing equipment and material handling equipment, and similar hazards shall be guarded with a standard guardrail system.

(2) Regardless of height employees shall be protected from falling into or onto impalement hazards, such as: reinforcing steel (rebar), or exposed steel or wood stakes used to set forms.

WAC 296-155-24509, Fall Protection Required at 4 Feet or More.

(1) The employer shall ensure that the appropriate fall protection system is provided, installed, and implemented according to the requirements in chapter 296-155 WAC, Part C-1 when employees are exposed to fall hazards of 4 feet or more to the ground or lower level when on a walking/working surface.

WAC 296-155-24509 (Cont.)

(2) Guarding of walking/working surfaces with unprotected sides and edges. Every open sided walking/working surface or platform 4 feet or more above adjacent floor or ground level shall be guarded by one of the following fall protection systems.

(a) A standard guardrail system, or the equivalent, as specified in WAC 296-155-24515(2), on all open sides, except where there is entrance to a ramp, stairway, or fixed ladder. The railing shall be provided with a standard toe board wherever, beneath the open sides, persons can pass, there is moving machinery, or there is equipment with which falling materials could create a hazard.

(i) When employees are using stilts, the height of the top rail or equivalent member of the standard guardrail system must be increased (or additional railings may be added) an amount equal to the height of the stilts while maintaining the strength specifications of the guardrail system.

(ii) Where employees are working on platforms above the protection of the guardrail system, the employer must either increase the height of the guardrail system as specified in WAC 296-155-24509(2)(a)(i), or select and implement another fall protection system as specified in WAC 296-155-24509 (2)(b)(c)(d)(e) or (f).

(iii) When guardrails must be temporarily removed to perform a specific task, the area shall be constantly attended by an employee until the guardrail is replaced. The only duty the employee shall perform is to prevent exposure to the fall hazard by warning persons entering the area of the fall hazard.

(b) A fall restraint system;

(c) A personal fall arrest system;

(d) A safety net system;

(e) A catch platform; and

(f) A warning lines

(3) Guarding of ramps, runways, and inclined walkways.

(a) Ramps, runways, and inclined walkways that are 4 feet or more above the ground or lower level shall be equipped with a standard guardrail system or the equivalent, as specified WAC 296-155-24515(2), along each open side. Wherever tools, machine parts, or materials are likely to be used on the runway, a toe board shall also be installed on each open side to protect persons working or passing below.

(b) Runways used exclusively for special purposes may have the railing on one side omitted where operating conditions necessitate such omission, providing the falling hazard is minimized by using a runway not less than 18 inches wide.

Note: See WAC 296-155-24519(1) for other specific criteria for ramps, runways, and inclined walkways.

(4) Guarding of floor holes. Floor holes, into which persons can accidentally walk, shall be guarded by either a standard guardrail system with standard toe board along all open sides, or a floor hole cover of standard strength and construction that is secured against accidental displacement. While the cover is not in place, the floor hole shall be protected by a standard guardrail system.

(5) Guarding of floor openings.

(a) Floor openings shall be guarded by one of the following fall restraint systems.

(i) A standard guardrail system, or the equivalent, as specified in WAC 296-155-24515(2), on all open sides, except where there is entrance to a ramp, stairway, or fixed ladder. The railing shall be provided with a standard toe board wherever, beneath the open sides, persons can pass, or there is moving machinery, or there is equipment with which falling materials could create a hazard.

(ii) A cover, as specified in WAC 296-155-24515(3);

(iii) A warning line system erected at least 15 feet from all unprotected sides or edges of the floor opening and meets the requirements of WAC 296-155-24515(4).

(iv) If it becomes necessary to remove the cover, the guardrail system, or the warning line system, then an employee shall remain at the opening until the cover, guardrail system, or warning line system is replaced. The only duty the

WAC 296-155-24509 (Cont.)

employee shall perform is to prevent exposure to the fall hazard by warning persons entering the area of the fall hazard.

(b) Ladderway floor openings or platforms shall be guarded by standard guardrail system with standard toe boards on all exposed sides, except at entrance to opening, with the passage through the railing either provided with a swinging gate or so offset that a person cannot walk directly into the opening.

(c) Hatchways and chute floor openings shall be guarded by one of the following:

(i) Hinged covers of standard strength and construction and a standard guardrail system with only one exposed side. When the opening is not in use, the cover shall be closed or the exposed side shall be guarded at both top and intermediate positions by removable standard guardrail systems;

(ii) A removable standard guardrail system with toe board on not more than two sides of the opening and fixed standard guardrail system with toe boards on all other exposed sides. The removable railing shall be kept in place when the opening is not in use and shall be hinged or otherwise mounted so as to be conveniently replaceable.

(d) Wherever there is a danger of falling through an unprotected skylight opening, or the skylight has been installed and is not capable of sustaining the weight of a two hundred pound person with a safety factor of four, standard guardrails shall be provided on all exposed sides in accordance with WAC 296-155-24515(2) or the skylight shall be covered in accordance with WAC 296-155-24515(3). Personal fall arrest equipment may be used as an equivalent means of fall protection when worn by all employees exposed to the fall hazard.

(e) Pits and trap door floor openings shall be guarded by floor opening covers of standard strength and construction. While the cover is not in place, the pit or trap openings shall be protected on all exposed sides by removable standard guardrail system.

(f) Manhole floor openings shall be guarded by standard covers which need not be hinged in place. While the cover is not in place, the manhole opening shall be protected by standard guardrail system.

(6) Guarding of wall openings.

(a) Wall openings, from which there is a fall hazard of 4 feet or more, and the bottom of the opening is less than 39 inches above the working surface, shall be guarded as follows:

(i) When the height and placement of the opening in relation to the working surface is such that either a standard rail or intermediate rail will effectively reduce the danger of falling, one or both shall be provided;

(ii) The bottom of a wall opening, which is less than 4 inches above the working surface, regardless of width, shall be protected by a standard toe board or an enclosing screen either of solid construction or as specified in WAC 296-155-24515(2)(c).

(b) An extension platform, outside a wall opening, onto which materials can be hoisted for handling shall have standard guardrails on all exposed sides or equivalent. One side of an extension platform may have removable railings in order to facilitate handling materials.

(c) When a chute is attached to an opening, the provisions of WAC 296-155-24509(4)(c) shall apply, except that a toe board is not required.

(7) Fall protection during form and rebar work. When exposed to a fall height of 4 feet or more, employees placing or tying reinforcing steel on a vertical face are required to be protected by personal fall arrest systems, safety net systems, or positioning device systems.

(8) Fall protection on steep-pitched and low-pitched roofs.

(a) Steep-pitched roofs. Regardless of the work activity, employers shall ensure that employees exposed to fall hazards of 4 feet or more while working on a roof with a pitch greater than 4:12 use one of the following:

(i) Fall restraint system. Safety monitors and warning line systems are prohibited on steep-pitched roofs;

WAC 296-155-24509 (Cont.)

- (ii) Fall arrest system; or
- (iii) Positioning device system.

(b) Low-pitched roofs. Employers shall ensure that employees exposed to fall hazards of 4 feet or more while engaged in work, other than roofing work or leading edge work, on low pitched roofs use one of the following:

- (i) Fall restraint system;
- (ii) Fall arrest system;
- (iii) Positioning device system;
- (iv) Safety monitor and warning line system; or
- (v) Safety watch system

(9) Hazardous slopes. Employees exposed to falls of 4 feet or more while working on a hazardous slope shall use personal fall arrest systems or positioning device systems.

WAC 296-155-24511, Fall Protection Required at 10 Feet or More.

(1) The employer shall ensure that the appropriate fall protection system is provided, installed, and implemented according to the requirements in chapter 296-155 WAC, Part C-1 when employees are exposed to fall hazards of 10 feet or more to the ground or lower level, while:

- (a) Engaged in roofing work on a low-pitched roof;
- (b) Constructing a leading edge on low pitched surfaces.

Note: Employees not directly involved with constructing the leading edge, or are not performing roofing work must comply with WAC 296-155-24509, Fall Protection Required at 4 Feet.

(c) Working on any surface that does not meet the definition of a walking/working surface not already covered in WAC 296-155-24509;

(d) Engaged in excavation and trenching operations.

- (i) Exceptions. Fall protection is not required at excavations when employees are:
 - (A) Directly involved with the excavation process and on the ground at the top edge of the excavation; or
 - (B) Working at an excavation site where appropriate sloping of side walls has been implemented as the excavation protective system.
- (ii) Fall protection is required for employees standing in or working in the affected area of a trench or excavation exposed to a fall hazard of 10 feet or more and:
 - (A) The employees are not directly involved with the excavation process; or
 - (B) The employees are on the protective system or any other structure in the excavation.

Note: Persons considered directly involved in the excavation process include:

- Foreman of the crew
- Signal person
- Employee hooking on pipe or other materials
- Grade person
- State, county, or city inspectors inspecting the excavation or trench
- An engineer or other professional conducting a quality-assurance inspection.

(2) Fall Protection Work Plan. The employer shall develop and implement a written fall protection work plan including each area of the work place where the employees are assigned and where fall hazards of 10 feet or more exist.

(a) The fall protection work plan shall:

- (i) Identify all fall hazards in the work area;
- (ii) Describe the method of fall arrest or fall restraint to be provided;
- (iii) Describe the proper procedures for the assembly, maintenance, inspection, and disassembly of the fall protection system to be used;
- (iv) Describe the proper procedures for the handling, storage, and securing of tools and materials;

WAC 296-155-24511 (Cont.)

- (v) Describe the method of providing overhead protection for workers who may be in, or pass through the area below the work site;
 - (vi) Describe the method for prompt, safe removal of injured workers; and
 - (vii) Be available on the job site for inspection by the department.
- (b) Prior to permitting employees into areas where fall hazards exist the employer shall ensure employees are trained and instructed in the items described in WAC 296-155-24511(2)(a)(i) through (2)(a)(vii).

WAC 296-155-24513, Fall Arrest Specifications. Fall arrest protection shall conform to the following provisions:

(1) Personal fall arrest system shall consist of:

- (a) A full body harness shall be used.
- (b) Full body harness systems or components subject to impact loading shall be immediately removed from service and shall not be used again for employee protection unless inspected and determined by a competent person to be undamaged and suitable for reuse.
- (c) Anchorages for full body harness systems shall be capable of supporting (per employee):
 - (i) 3000 lbs when used in conjunction with:
 - (A) A self retracting lifeline that limits the maximum free fall distances to 2 feet or less, or
 - (B) A shock absorbing lanyard that restricts the forces on the body to 900 lbs or less.
 - (ii) 5000 lbs for all other personal fall arrest system applications, or they shall be designed, installed, and used:
 - (A) As a part of a complete personal fall arrest system which maintains a safety factor of at least two, and
 - (B) Under the supervision of a qualified person.
- (d) When stopping a fall, personal fall arrest systems must:
 - (i) Be rigged to allow a maximum free fall distance of 6 feet so an employee will not contact any lower level.
 - (ii) Limit maximum arresting force on an employee to 1,800 pounds (22.2kN).
 - (iii) Bring an employee to a complete stop and limit maximum deceleration distance an employee travels to 3.5 feet (1.07 m); and
 - (iv) Have sufficient strength to withstand twice the potential impact energy of an employee free falling a maximum distance of 6 feet (1.8 m).

Notes:

- Shock absorbers that meet the requirements of ANSI Z359.1 -2007 that are used as a part of a personal fall arrest system in accordance with manufacturer's recommendations and instructions for use and installation will limit the maximum arresting forces on an employee's body to 1,800 pounds or less.
 - To calculate fall clearance distance using a shock absorbing lanyard and d-ring anchorage connector, see Appendix-B
- (e) All safety lines and lanyards shall be protected against being cut or abraded.
- (f) The attachment point of the full body harness shall be located in the center of the wearer's back near shoulder level, or above the wearer's head.
- (g) Hardware shall be drop forged, pressed or formed steel, or made of materials equivalent in strength.
- (h) Hardware shall have a corrosion resistant finish, and all surfaces and edges shall be smooth to prevent damage to the attached full body harness or lanyard.
- (i) When vertical lifelines (droplines) are used, not more than one employee shall be attached to any one lifeline.

WAC 296-155-24513 (Cont.)

Note: The system strength needs in the following items are based on a total combined weight of employee and tools of no more than 310 pounds. If combined weight is more than 310 pounds, appropriate allowances must be made or the system will not be in compliance. For more information on system testing see WAC 296-24-88050, Appendix C, Part II.

- (j) Vertical lifelines (droplines) shall have a minimum breaking strength of 5,000 pounds (22.2 kN), except that self retracting lifelines and lanyards which automatically limit free fall distance to 2 feet (.61 m) or less shall have a minimum breaking strength of 3,000 pounds (13.3 kN).
- (k) Horizontal lifelines shall be designed, installed, and used, under the supervision of a qualified person, as part of a complete personal fall arrest system, which maintains a safety factor of at least two.
- (l) Droplines or lifelines used on rock scaling operations, or in areas where the lifeline may be subjected to cutting or abrasion, shall be a minimum of 7/8 inch wire core manila rope. For all other lifeline applications, a minimum of 3/4 inch manila or equivalent, with a minimum breaking strength of 5,000 pounds, shall be used.
- (m) Lanyards shall have a minimum breaking strength of 5000 pounds (22.2 kN).
- (n) All components of full body harness systems whose strength is not otherwise specified in this subsection shall be capable of supporting a minimum fall impact load of 5,000 pounds (22.2 kN) applied at the lanyard point of connection.
- (o) D-rings and snap-hooks shall be proof-tested to a minimum tensile load of 3600 pounds (16 kN) without cracking, breaking, or taking permanent deformation.
- (p) Snap-hooks shall be a locking type snap-hook designed and used to prevent disengagement of the snap-hook by the contact of the snap-hook keeper by the connected member.
- (q) Unless the snap-hook is designed for the following connections, snap-hooks shall not be engaged:
 - (i) Directly to the webbing, rope or wire rope;
 - (ii) To each other;
 - (iii) To a D-ring to which another snap-hook or other connector is attached;
 - (iv) To a horizontal lifeline; or
 - (v) To any object which is incompatibly shaped or dimensioned in relation to the snap-hook such that unintentional disengagement could occur by the connected object being able to depress the snap-hook keeper and release itself.
- (2) Safety net systems. Safety net systems and their use shall comply with the following provisions:
 - (a) Safety nets shall be installed as close as practicable under the surface on which employees are working, but in no case more than 30 feet (9.1 m) below such level unless specifically approved in writing by the manufacturer. The potential fall area to the net shall be unobstructed.
 - (b) Safety nets shall extend outward from the outermost projection of the work surface as follows:

Vertical distance from working levels to horizontal plane of net	Minimum required horizontal distance of outer edge of net from the edge of the working surface
Up to 5 feet	8 feet
More than 5 feet up to 10 feet	10 feet
More than 10 feet	13 feet

WAC 296-155-24513 (Cont.)

- (c) Safety nets shall be installed with sufficient clearance under them to prevent contact with the surface or structures below when subjected to an impact force equal to the drop test specified in WAC 296-155-24513(2)(d).
 - (d) Safety nets and their installations shall be capable of absorbing an impact force equal to that produced by the drop test.
 - (i) Except as provided in WAC 296-155-24513(2)(d)(ii), safety nets and safety net installations shall be drop-tested at the job site after initial installation and before being used as a fall protection system, whenever relocated, after major repair, and at 6-month intervals if left in one place. The drop-test shall consist of a 400 pound (180 kg) bag of sand 30 ± 2 inches (76 ± 5 cm) in diameter dropped into the net from the highest walking/working surface at which employees are exposed to fall hazards, but not from less than 42 inches (1.1 m) above that level.
 - (ii) When the employer can demonstrate that it is unreasonable to perform the drop-test required by WAC 296-155-24513(2)(d)(i), the employer (or a designated competent person) shall certify that the net and net installation is in compliance with WAC 296-155-24513(2)(c) and (2)(d)(i) by preparing a certification record prior to the net being used as a fall protection system. The certification record must include an identification of the net and net installation for which the certification record is being prepared; the date that it was determined that the identified net and net installation were in compliance with WAC 296-155-24513(2)(c) and the signature of the person making the determination and certification. The most recent certification record for each net and net installation shall be available at the job site for inspection.
 - (e) Materials, scrap pieces, equipment, and tools which have fallen into the safety net shall be removed as soon as possible from the net and at least before the next work shift.
 - (f) The maximum size of each safety net mesh opening shall not exceed 36 square inches (230 cm²) nor be longer than 6 inches (15 cm) on any side, and the opening, measured center-to-center of mesh ropes or webbing, shall not be longer than 6 inches (15 cm). All mesh crossings shall be secured to prevent enlargement of the mesh opening.
 - (g) Each safety net (or section of it) shall have a border rope or webbing with a minimum breaking strength of 5,000 pounds (22.2 kN).
 - (h) Connections between safety net panels shall be as strong as integral net components and shall be spaced not more than 6 inches (15 cm) apart.
- (3) Catch platforms.
- (a) A catch platform shall be installed within 4 vertical feet of the work area.
 - (b) The catch platforms width shall be a minimum of 45 inches wide and shall be equipped with standard guardrails and toe boards on all open sides.

WAC 296-155-24515, Fall Restraint Specifications. Fall restraint protection shall conform to the following provisions:

- (1) Personal fall restraint systems shall be rigged to allow the movement of employees only as far as the unprotected sides and edges of the walking/working surface, and shall consist of:
 - (a) A full body harness shall be used.
 - (b) The full body harness must be attached to securely rigged restraint lines.
 - (c) All hardware assemblies for full body harness shall be capable of withstanding a tension loading of 4,000 pounds without cracking, breaking, or taking a permanent deformation.
 - (d) The employer shall ensure component compatibility.
 - (e) Anchorage points used for fall restraint shall be capable of supporting 4 times the intended load.
 - (f) Rope grab devices are prohibited for fall restraint applications unless they are part of a fall restraint system designed specifically for the purpose by the manufacturer, and used in strict accordance with the manufacturer's recommendations and instructions.

WAC 296-155-24515 (Cont.)

(2) Guardrail specifications.

(a) A standard guardrail system shall consist of top rail, intermediate rail, and posts, and shall have a vertical height of 39-45 inches from upper surface of top rail to floor, platform, runway, or ramp level. When conditions warrant, the height of the top edge may exceed the 45-inch height, provided the guardrail system meets all other criteria of this subsection. The intermediate rail shall be halfway between the top rail and the floor, platform, runway, or ramp. The ends of the rails shall not overhang the terminal posts except where such overhang does not constitute a projection hazard.

(b) Minimum requirements for standard guardrail systems under various types of construction are specified in the following items:

(i) For wood railings, the posts shall be of at least 2 inch by 4 inch stock spaced not to exceed 8 feet; the top rail shall be of at least 2 inch by 4 inch stock and each length of lumber shall be smooth surfaced throughout the length of the railing. The intermediate rail shall be of at least 1 inch by 6 inch stock. Other configurations may be used for the top rail when the configuration meets the requirements of WAC 296-155-24515(2)(b)(vii).

(ii) For pipe railings, posts and top and intermediate railings shall be at least 1 1/2 inches nominal OD diameter with posts spaced not more than 8 feet on centers. Other configurations may be used for the top rail when the configuration meets the requirements of WAC 296-155-24515(2)(b)(vii).

(iii) For structural steel railings, posts and top and intermediate rails shall be of 2 inch by 2 inch by 3/8 inch angles or other metal shapes of equivalent bending strength, with posts spaced not more than 8 feet on centers. Other configurations may be used for the top rail when the configuration meets the requirements of WAC 296-155-24515(2)(b)(vii).

(iv) For wire rope railings, the top and intermediate railings shall meet the strength factor and deflection of WAC 296-155-24515(2)(b)(v). The top railing shall be flagged at not more than 6 foot intervals with high-visibility material. Posts shall be spaced not more than 8 feet on centers. The rope shall be stretched taut and shall be between 39 and 45 inches in height at all points. Other configurations may be used for the top rail when the configuration meets the requirements of WAC 296-155-24515(2)(b)(vii).

(v) The anchoring of posts and framing of members for railings of all types shall be of such construction that the completed structure shall be capable of withstanding a load of at least 200 pounds applied in any direction at any point on the top rail. The top rail shall be between 39 and 45 inches in height at all points when this force is applied.

(vi) Railings receiving heavy stresses from employees trucking or handling materials shall be provided additional strength by the use of heavier stock, closer spacing of posts, bracing, or by other means.

(vii) Other types, sizes, and arrangements of railing construction are acceptable, provided they meet the following conditions:

- (A) A smooth surfaced top rail at a height above floor, platform, runway, or ramp level of between 39 - 45 inches;
- (B) When the 200-pound (890N) load specified in WAC 296-155-24515(2)(b)(v) is applied in a downward direction, the top edge of the guardrail shall not deflect to a height less than 39 inches (1.0m) above the walking/working level. Guardrail system components selected and constructed in accordance with this part will be deemed to meet this requirement.
- (C) Protection between top rail and floor, platform, runway, ramp, or stair treads, equivalent at least to that afforded by a standard intermediate rail;
- (D) Elimination of overhang of rail ends unless such overhang does not constitute a hazard.

WAC 296-155-24515 (Cont.)

- (c) Toe board specifications.
 - (i) A standard toe board shall be 4 nominal inches minimum in vertical height from its top edge to the level of the floor, platform, runway, or ramp. It shall be securely fastened in place and have not more than 1/4 inch clearance above floor level. It may be made of any substantial material, either solid, or with openings not over 1 inch in greatest dimension.
 - (ii) Where material is piled to such height that a standard toe board does not provide protection, paneling, or screening from floor to intermediate rail or to top rail shall be provided.
- (3) Cover specifications.
 - (a) Floor opening or floor hole covers shall be of any material that meets the following strength requirements:
 - (i) Conduits, trenches, and manhole covers and their supports, when located in roadways, and vehicular aisles shall be designed to carry a truck rear axle load of at least 2 times the maximum intended load;
 - (ii) All floor opening and floor hole covers shall be capable of supporting the maximum potential load but never less than two hundred pounds (with a safety factor of four).
 - (A) All covers shall be secured when installed so as to prevent accidental displacement by the wind, equipment, or employees.
 - (B) All covers shall be color coded or they shall be marked with the word "hole" or "cover" to provide warning of the hazard.
 - (b) Barriers and screens used to cover wall openings shall meet the following requirements:
 - (i) Barriers shall be of such construction and mounting that, when in place at the opening, the barrier is capable of withstanding a load of at least 200 pounds applied in any direction (except upward), with a minimum of deflection at any point on the top rail or corresponding member.
 - (ii) Screens shall be of such construction and mounting that they are capable of withstanding a load of at least 200 pounds applied horizontally at any point on the near side of the screen. They may be of solid construction of either grill work with openings not more than 8 inches long, or of slat work with openings not more than 4 inches wide with length unrestricted.
- (4) Warning line system specifications on pitches 4 x 12 or less for roofing work, leading edge work, and on low pitched open sided surfaces for work activities other than roofing work or leading edge work. The employer shall ensure the following:
 - (a) Warning lines shall be erected around all unprotected sides and edges of the work area.
 - (i) Warning lines used during roofing work.
 - (A) When roofing work is taking place or when mechanical equipment is not being used, the warning line shall be erected not less than 6 feet (1.8 meters) from the edge of the roof.
 - (B) When mechanical equipment is being used, the warning line shall be erected not less than 6 feet (1.8 meters) from the roof edge which is parallel to the direction of mechanical equipment operation, and not less than 10 feet (3.1 meters) from the roof edge which is perpendicular to the direction of mechanical equipment operation.
 - (ii) Warning lines erected for leading edge work. Warning lines shall be erected to separate employees who are engaged in leading edge work (between the forward edge of the warning line and the leading edge), from other work areas on the low pitched surface. The employer shall ensure:
 - (A) The warning line is erected not less than 6 feet nor more than 25 feet from the leading edge; and
 - (B) When fall arrest systems as described in WAC 296-155-24513, or fall restraint systems as described in WAC 296-155-24515(1) and (2) are not used, a safety monitor system as described in WAC 296-155-24515(5) shall be implemented to protect employees engaged in constructing the leading edge who are working between the forward edge of the warning line and the leading edge.

WAC 296-155-24515 (Cont.)

(iii) Warning lines erected on low-pitched open sided surfaces for work activities other than roofing work or leading edge work, shall be erected not less than 15 feet from the unprotected sides or edges of the open sided surface.

(b) The warning line shall consist of a rope, wire, or chain and supporting stanchions erected as follows:

(i) The rope, wire, or chain shall be flagged at not more than six foot (1.8 meter) intervals with high visibility material. Highly visible caution or danger tape as described in WAC 296-155-24515(4)(b)(iv), does not need to be flagged.

(ii) The rope, wire, or chain shall be rigged and supported in such a way that its lowest point (including sag) is no less than 39 inches from the surface and its highest point is no more than 45 inches from the surface.

(iii) After being erected, with the rope, wire or chain attached, stanchions shall be capable of resisting, without tipping over, a force of at least 16 pounds (71 Newtons) applied horizontally against the stanchion, 30 inches (0.76 meters) above the surface, perpendicular to the warning line, and in the direction of the unprotected sides or edges of the surface.

(iv) The rope, wire, or chain shall have a minimum tensile strength of 200 pounds (90 kilograms), and after being attached to the stanchions, shall be capable of supporting, without breaking, the loads applied to the stanchions. Highly visible caution or danger tape may be used in lieu of rope, wire, or chain as long as it is at least 3 inches wide and 3 mils thick, and has a tensile strength of at least of 200 pounds.

(v) The line shall be attached at each stanchion in such a way that pulling on one section of the line between stanchions will not result in slack being taken up in adjacent sections before the stanchion tips over.

(c) Access paths shall be erected as follows:

(i) Points of access, materials handling areas, and storage areas shall be connected to the work area by a clear access path formed by two warning lines.

(ii) When the path to a point of access is not in use, a rope, wire, or chain, equal in strength and height to the warning line, shall be placed across the path at the point where the path intersects the warning line erected around the work area.

(5) Safety monitor system specifications.

(a) A safety monitor system may be used in conjunction with a warning line system as a method of fall protection during roofing work on low pitched roofs or leading edge work on low pitched surfaces.

Note: The warning line is not required when performing roofing work on low-pitched roofs less than 50 feet wide. For information on determining roof widths, see Appendix A, Determining roof widths.

(b) When selected, the employer shall ensure that the safety monitor system is addressed in the fall protection work plan, including the name of the safety monitor(s) and the extent of their training in both the safety monitor and warning line systems. The employer shall ensure that the following requirements are met:

(i) The safety monitor system shall not be used when adverse weather conditions create additional hazards.

(ii) Employees working outside of the warning line system, (between the forward edge of the warning line and the unprotected sides or edges of a low pitched surface), shall be readily distinguishable from other members of the crew that are working inside the warning line system by wearing highly visible, distinctive, and uniform apparel.

(iii) Employees must promptly comply with fall hazard warnings from the safety monitor.

(iv) A person acting in the capacity of safety monitor(s) shall be trained in the function of both the safety monitor and warning lines systems, and shall:

(A) Be a competent person as defined in WAC 296-155-24503(5).

WAC 296-155-24515 (Cont.)

- (B) Have control authority over the work as it relates to fall protection.
 - (C) Be instantly distinguishable over members of the work crew.
 - (D) Perform no other duties while acting as safety monitor.
 - (E) Be positioned in relation to the workers under their protection, so as to have a clear, unobstructed view and be able to maintain normal voice communication.
 - (F) Not supervise more than eight exposed workers at one time.
 - (G) Warn the employee when it appears that the employee is unaware of a fall hazard or is acting in an unsafe manner.
- (6) Safety watch system specifications.
- (a) When one employee is conducting any repair work or servicing equipment on a roof that has a pitch no greater than 4:12, employers are allowed to use a safety watch system.
 - (b) Ensure the safety watch system meets the following requirements:
 - (i) There can only be two people on the roof while the safety watch system is being used: the one employee acting as the safety watch and the one employee engaged in the repair work or servicing equipment.
 - (ii) The employee performing the task must comply promptly with fall hazard warnings from the safety watch;
 - (iii) Mechanical equipment is not used; and
 - (iv) The safety watch system is not used when weather conditions create additional hazards.
 - (c) Ensure the employee acting as the safety watch meets all of the following:
 - (i) Is a competent person as defined in WAC 296-155-24503(5);
 - (ii) Has full control over the work as it relates to fall protection;
 - (iii) Has a clear, unobstructed view of the worker;
 - (iv) Is able to maintain normal voice communication; and
 - (v) Performs no other duties while acting as the safety watch.

WAC 296-155-24517, Positioning Device System Specifications. Positioning device systems and their use shall conform to the following provisions:

- (1) Positioning harnesses or full body harnesses shall be used.
- (2) Positioning devices shall be rigged to prevent an employee from a free fall greater than 2 feet.
- (3) Positioning devices shall be secured to an anchorage capable of supporting at least twice the potential impact load of an employee's fall or 3,000 pounds (13.3 kN), whichever is greater.
- (4) Connectors shall be drop forged, pressed or formed steel, or made of equivalent materials.
- (5) Connectors shall have a corrosion-resistant finish, and all surfaces and edges shall be smooth to prevent damage to interfacing parts of this system.
- (6) Connecting assemblies shall have a minimum breaking strength of 5,000 pounds (22.2 kN).
- (7) D-rings and snap-hooks shall be proof-tested to a minimum tensile load of 3,600 pounds (16 kN) without cracking, breaking, or taking permanent deformation.
- (8) Snap-hooks shall be a locking type snap-hook designed and used to prevent disengagement of the snap-hook by the contact of the snap-hook keeper by the connected member.
- (9) Unless the snap-hook is designed for the following connections, snap-hooks shall not be engaged:
 - (a) Directly to webbing, rope or wire rope;
 - (b) To each other;
 - (c) To a D-ring to which another snap-hook or other connector is attached;

WAC 296-155-24517 (Cont.)

- (d) To a horizontal lifeline; or
- (e) To any object which is incompatibly shaped or dimensioned in relation to the snap-hook such that unintentional disengagement could occur by the connected object being able to depress the snap-hook keeper and release itself.

WAC 296-155-24519, Other Specifications.

(1) Ramps, runways and inclined walkways shall:

(a) Be at least 18 inches wide, and

(b) Not be inclined more than twenty degrees from horizontal and when inclined, they shall be cleated or otherwise treated to prevent a slipping hazard on the walking surface.

Note: See WAC 296-155-24509(3) for guarding ramps, runways, and inclined walkways that are 4 feet or more above the ground or lower level.

(2) Self-rescue devices. Self-rescue devices are not a fall protection system. Self-rescue devices used to self-rescue after a fall shall meet the following requirements.

(a) Use self-rescue devices according to the manufacturer's instructions, and

(b) Self-rescue devices must be addressed by the fall protection work plan.

(3) Canopy. Canopies, when used as falling object protection, shall be strong enough to prevent collapse and to prevent penetration by any objects which may fall onto the canopy.

(4) Roofing bracket specifications. Roofing brackets are not a fall protection system.

(a) Roofing brackets shall be constructed to fit the pitch of the roof.

(b) In addition to securing brackets using the pointed metal projections, brackets shall also be secured in place by nailing. When it is impractical to nail brackets, rope supports shall be used. When rope supports are used, they shall consist of first grade manila of at least 3/4 inch diameter, or equivalent.

(5) Crawling board and chicken ladder specifications. Crawling boards and chicken ladders are not fall protection systems.

(a) Crawling boards shall be not less than 10 inches wide and one inch thick, having cleats 1 x 1 1/2 inches.

(i) The cleats shall be equal in length to the width of the board and spaced at equal intervals not to exceed 24 inches.

(ii) Nails shall be driven through and clinched on the underside.

(iii) The crawling board shall extend from the ridge pole to the eaves when used in connection with roof construction, repair, or maintenance.

(b) Crawling boards shall be secured to the roof using ridge hooks or other equivalent means.

(6) Roof edge materials handling areas and materials storage specifications.

(a) When guardrails are used at hoisting areas, a minimum of four feet of guardrail shall be erected along each side of the access point through which materials are hoisted.

(b) A chain or gate shall be placed across the opening between the guardrail sections when hoisting operations are not taking place.

(c) When guardrails are used at bitumen pipe outlet, a minimum of four feet of guardrail shall be erected along each side of the pipe.

(d) Mechanical equipment shall be used or stored only in areas where employees are protected using a fall arrest system as described in WAC 296-155-24513, or a fall restraint system as described WAC 296-155-24515(1), (2), or (4).

Mechanical equipment may not be used or stored where the only protection is provided by the use of a safety monitor.

(e) The hoist shall not be used as an attachment/anchorage point for fall arrest or fall restraint systems.

WAC 296-155-24519 (Cont.)

(f) Materials shall not be stored within six feet of the roof edge unless guardrails are erected at the roof edge. Guardrails shall include a toeboard if employees could be working or passing below.

WAC 296-155-24521, Training

(1) Training of employees.

(a) The employer shall ensure that employees are trained as required by Part C-1, chapter 296-155WAC. Training shall be documented and shall be available on the job site.

(b) “Retraining.” When the employer has reason to believe that any affected employee who has already been trained does not have the understanding and skill required by WAC 296-155-24521(1)(a), the employer shall retrain each such employee. Circumstances where retraining is required include, but are not limited to, situations where:

- Changes in the workplace render previous training obsolete; or
- Changes in the types of fall protection systems or equipment to be used render previous training obsolete; or
- Inadequacies in an affected employee's knowledge or use of fall protection systems or equipment indicate that the employee has not retained the requisite understanding or skill.

DRAFT

WAC 296-155-24523, Appendix A: Determining roof widths- Non-mandatory guidelines for complying with WAC 296-155-24515(5).

(1) This appendix serves as a guideline to assist employers complying with the requirements of WAC 296-155-24515(5); which allows the use of a safety monitoring system alone as a means of providing fall protection during the performance of roofing operations on low-pitched roofs 50 feet (15.25 m) or less in width. Each example in the appendix shows a roof plan or plans and indicates where each roof or roof area is to be measured to determine its width. Section views or elevation views are shown where appropriate. Some examples show “correct” and “incorrect” subdivisions of irregularly shaped roofs divided into smaller, regularly shaped areas. In all examples, the dimension selected to be the width of an area is the lesser of the two primary dimensions of the area, as viewed from above. *Example A: Shows a simple rectangular roof. The width is the lesser of the two primary overall dimensions; which is also the case with roofs sloped toward or away from the roof center, as shown in Example B.*

(2) Many roofs are not simple rectangles. Such roofs may be broken down into subareas as shown in Example C. The process of dividing a roof area can produce many different configurations. Example C gives the general rule of using dividing lines of minimum length to minimize the size and number of the areas which are potentially less than 50 feet (15.25 m) wide. The intent is to minimize the number of roof areas where safety monitoring systems alone are sufficient protection.

(3) Roofs which are comprised of several separate, non-contiguous roof areas, as in Example D, may be considered as a series of individual roofs. Some roofs have penthouses, additional floors, courtyard openings, or similar architectural features; Example E shows how the rule for dividing roofs into subareas is applied to such configurations. Irregular, non-rectangular roofs must be considered on an individual basis, as shown in Example F.

Example A
Rectangular Shaped Roof

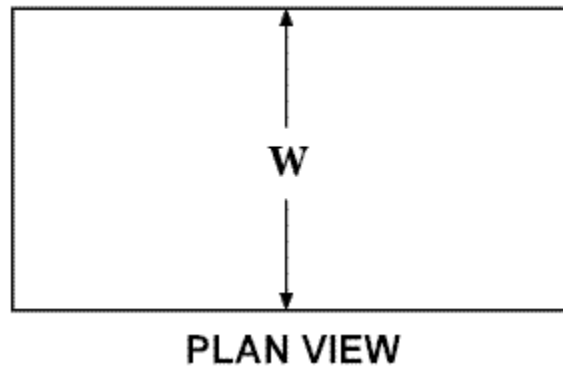

Example B
Sloped Rectangular Shaper Roofs

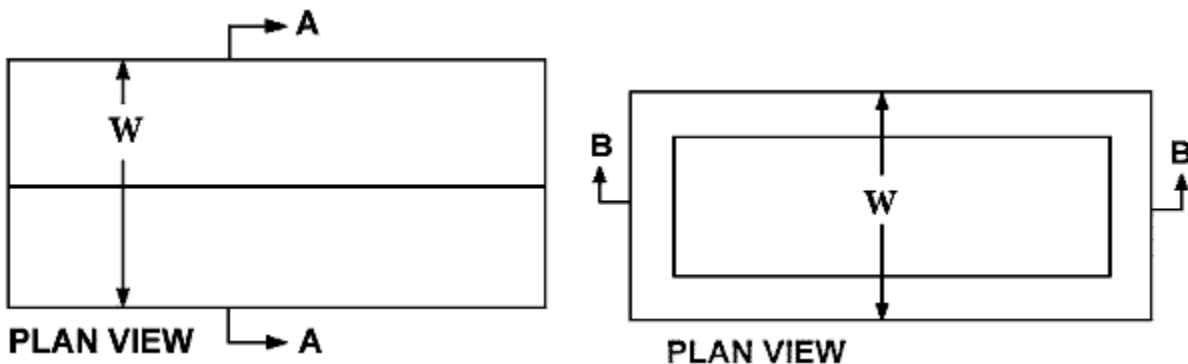

WAC 296-155-24523, Appendix A (Cont.)

Example B
Sloped Rectangular Shaper Roofs

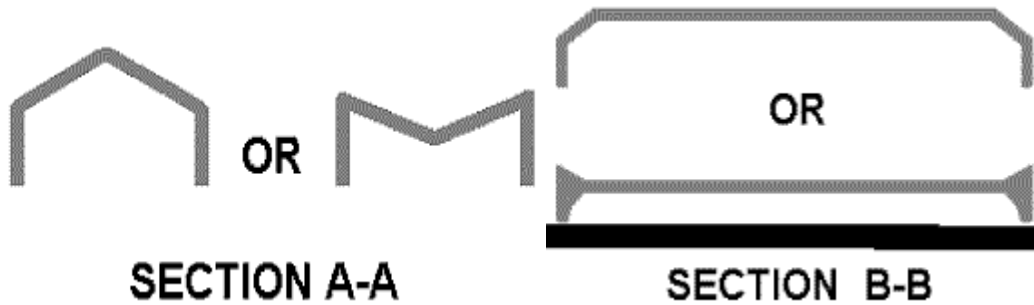

Example C
Irregularly Shaped Roofs with Rectangular Shaped Sections

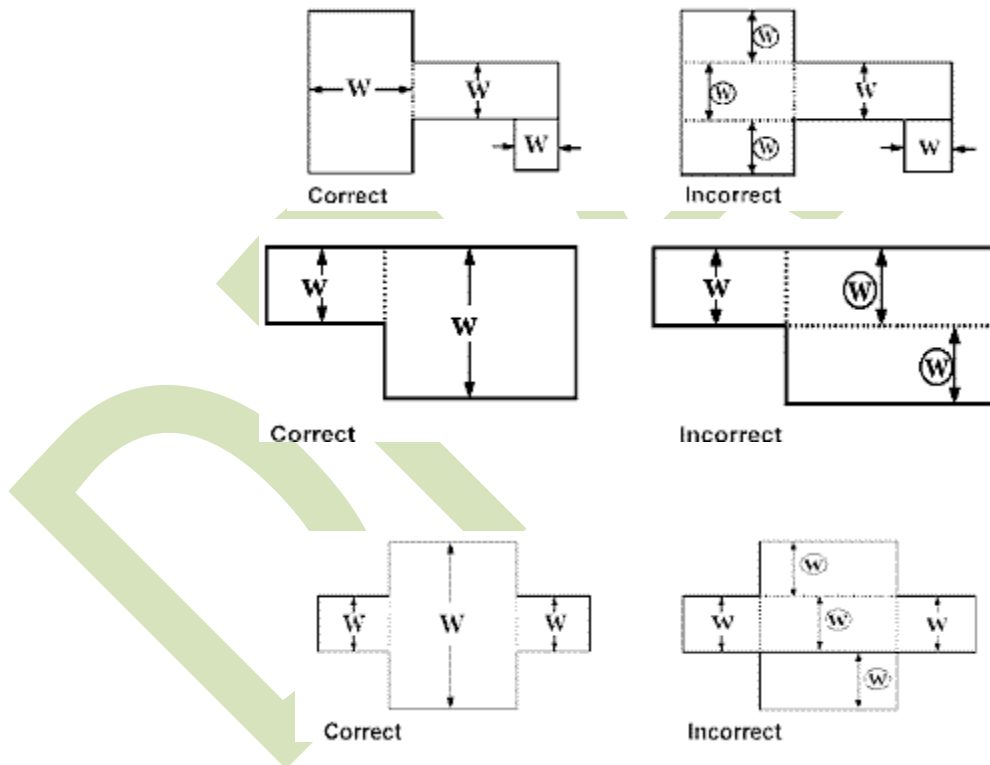

Such roofs are to be divided into subareas by using dividing lines of minimum length to minimize the size and number of the areas which are potentially less than or equal to 50 feet (15.25 meters) in width in order to limit the size of roof areas where the safety monitoring system alone can be used. Dotted lines are used in the examples to show the location of dividing lines.

Ⓜ Denotes incorrect measurements of width.

WAC 296-155-24523, Appendix A (Cont.)

Example D
Separate, Non-Contiguous Roof Areas

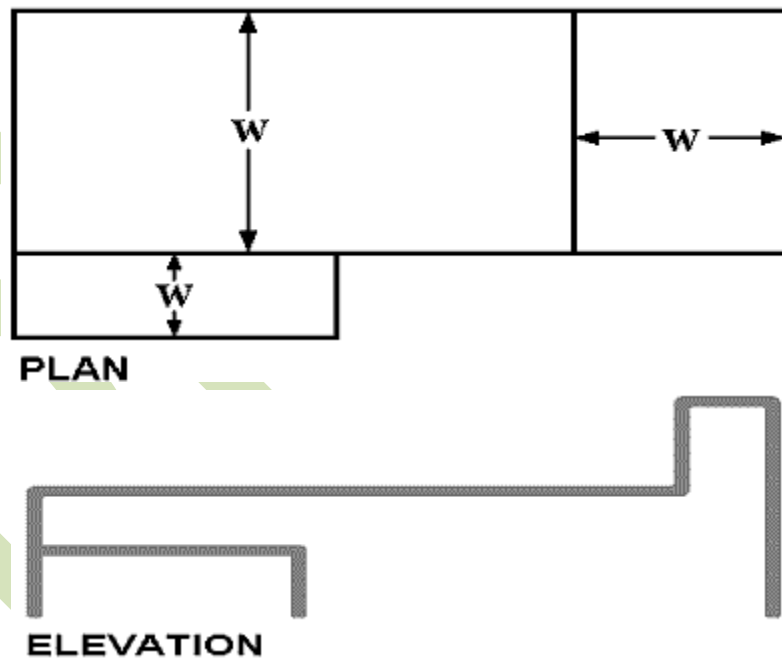
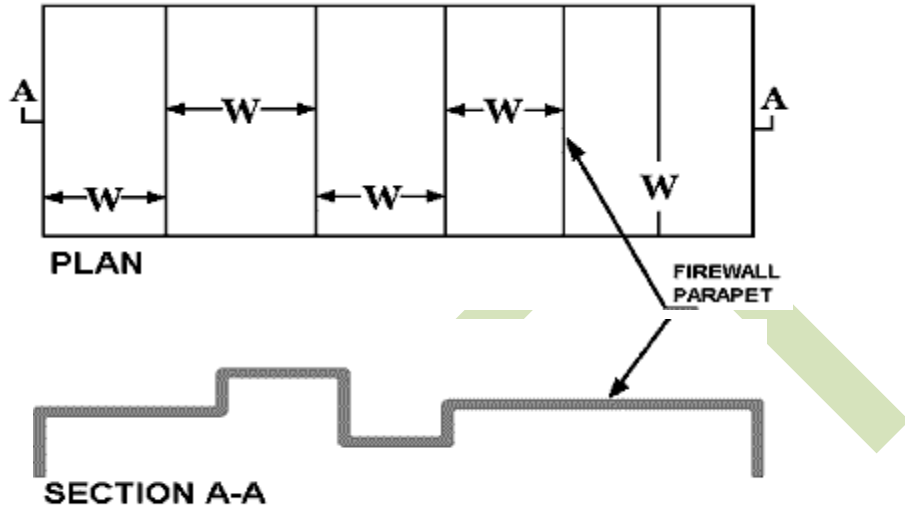

WAC 296-155-24523, Appendix A (Cont.)

Example E

Roofs with Penthouses, Open Courtyards, Additional Floors, etc.

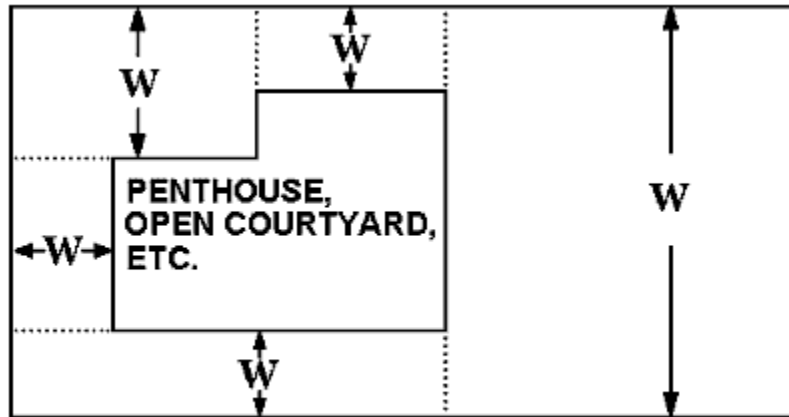

CORRECT

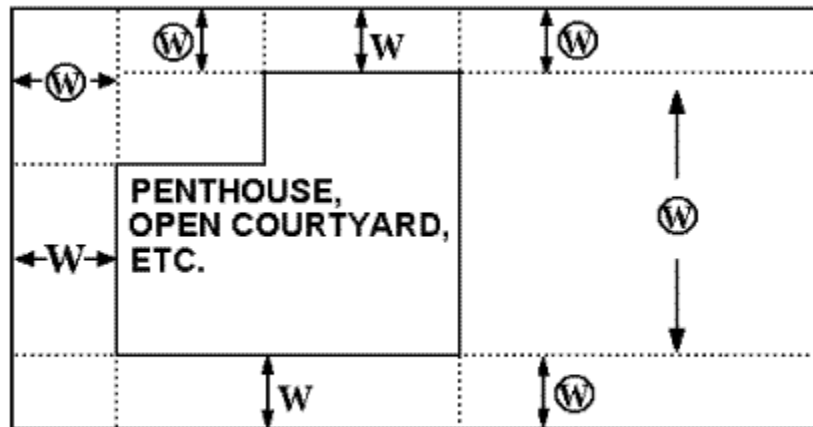

INCORRECT

Such roofs are to be divided into subareas by using dividing lines of minimum length to minimize the size and number of the areas which are potentially less than or equal to 50 feet (15.25 meters) in width in order to limit the size of roof areas where the safety monitoring system alone can be used. Dotted lines are used in the examples to show the location of dividing lines.

Ⓜ Denotes incorrect measurements of width.

WAC 296-155-24523, Appendix A (Cont.)

Example F
Irregular, Non-Rectangular Shaped Roofs

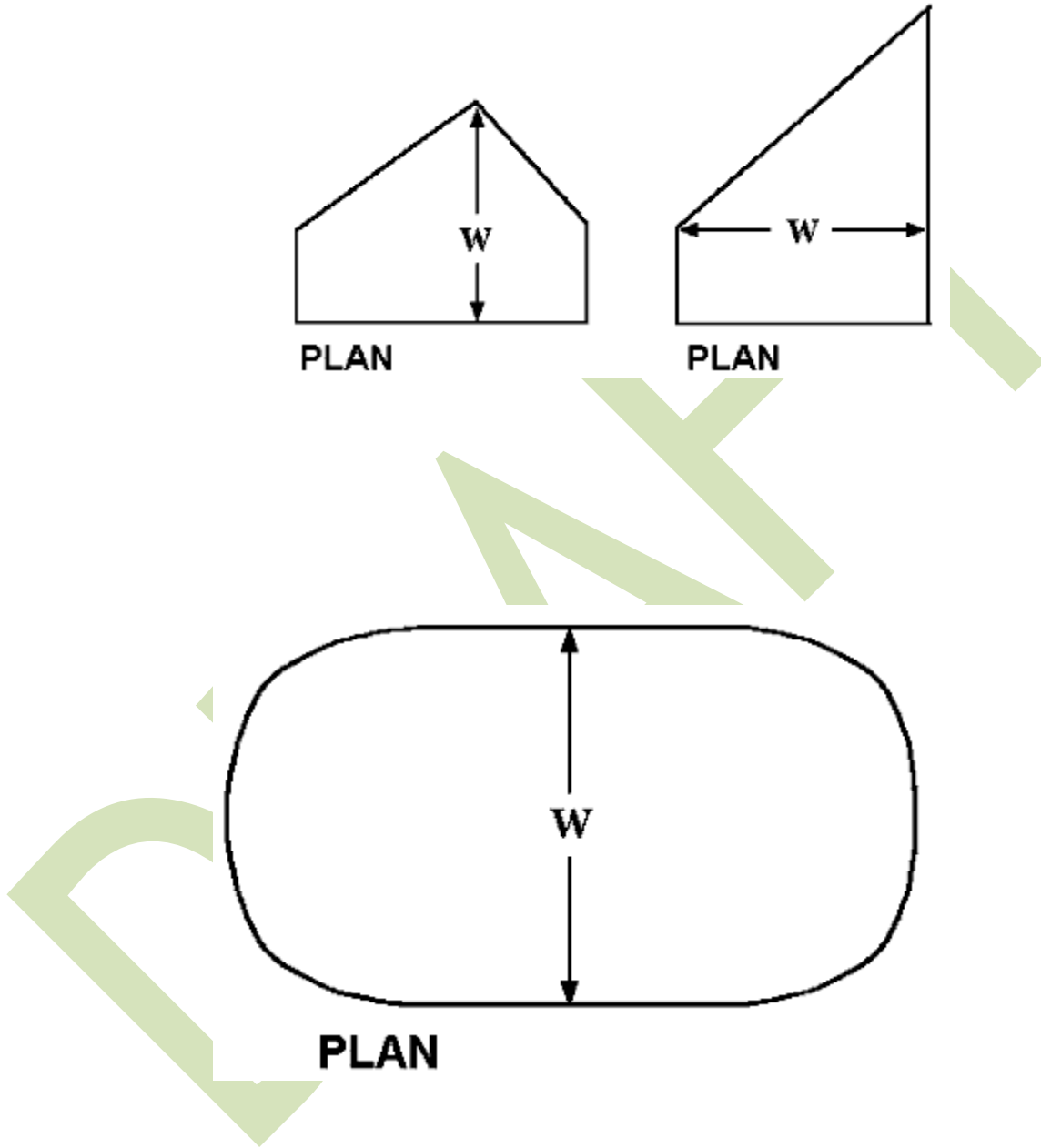

WAC 296-155-24524, Appendix-B: Calculating Fall Clearance Distance Using a Shock-Absorbing Lanyard and D-Ring Anchorage Connector – Non-mandatory guidelines for complying with WAC 296-155- 24513(1)(d).

Do the following to calculate the fall clearance distance using a shock absorbing lanyard and d-ring anchorage connector:

- First, add the length of the shock-absorbing lanyard (6 ft.) to the maximum elongation of the shock absorber during deceleration (3-1/2 ft.) to the average height of a worker (6 ft.).
- Then, add a safety factor of 3 ft. to allow for the possibility of an improperly fit full body harness, a taller than average worker and/or a miscalculation of distance.
- The suggested safe fall clearance distance for this example is 18 ½ feet.

