Chapter 296-59 WAC
SKI AREA FACILITIES AND OPERATIONS

WAC		Page
296-59-001	Foreword.	1
296-59-003	Scope and application.	1
296-59-005	Incorporation of other standards.	1
296-59-007	Definitions.	2
296-59-010	Safe place standards.	3
296-59-015	General requirements.	3
296-59-020	Management's responsibility.	3
296-59-025	Employee's responsibility.	4
296-59-027	Work activities which include skiing.	4
296-59-030	Safety bulletin board.	4
296-59-035	First-aid.	4
296-59-050	Personal protective equipment, general requirements.	4
296-59-055	Lockout requirements.	5
296-59-060	Vessel or confined area requirements.	8
296-59-065	Fire protection and ignition sources.	8
296-59-070	Illumination.	8
296-59-075	Electrical equipment and distribution.	9
296-59-080	Installation, inspection, and maintenance of pipes, piping systems, and hoses.	9
296-59-085	Scaffolds, construction, use, and maintenance.	11
296-59-090	Mobile equipment and lift trucks.	11
296-59-095	Requirements for cranes and hoists-General safety and health standards to prevail.	14
296-59-115	Ski lift facilities and structures.	14
296-59-120	Ski lift operations.	21
296-59-125	Ski lift aerial work platforms.	22
296-59-130	Ski lift machinery guarding.	24
296-59-135	Appendix 1-Nonmandatory alternative lockout procedure for ski lifts and tows.	24

WAC 296-59-001 Foreword.

- (1) This vertical standard is promulgated in accordance with applicable provisions of the Washington State Administrative Procedure Act, chapter 34.04 RCW, and the Washington Industrial Safety and Health Act, chapter 49.17 RCW.
- (2) The requirements of this chapter shall be applied through the department of labor and industries, division of industrial safety and health, in accordance with administrative procedures provided for in chapter 49.17 RCW, and chapters 296-27, 296-350, 296-360, and 296-800 WAC.

[Statutory Authority: RCW 49.17.010, .040, .050, 01-11-038 (Order 99-36), § 296-59-001, filed 05/09/01, effective 09/01/01. Statutory Authority: Chapter 49.17 RCW. 88-14-108 (Order 88-11), § 296-59-001, filed 7/6/88.]

WAC 296-59-003 Scope and application.

- (1) The rules of this chapter are applicable to all persons, firms, corporations, or others engaged in the operation of organized ski areas and facilities within the jurisdiction of the department of labor and industries. These rules shall augment the WAC general horizontal standards, specifically referenced WAC vertical standards, and specifically referenced national standards or manuals.
- (2) In the event that specific provisions of this chapter may conflict with any other WAC chapter, national standard, or manual, the provisions of this chapter shall prevail.
- (3) The rules of this chapter shall not be applied to rescue crews during the time that rescue procedures are in process provided that reasonably prudent methods, equipment, and processes are employed. Personnel directly engaged in rescue operations shall not be subjected to the immediate restraint provisions of RCW 49.17.130.
- (4) Nothing herein contained shall prevent the use of existing ski lift and tow equipment during its lifetime unless specific requirements of this chapter require retrofitting or modifications, provided that it shall be in conformance with applicable national or state code requirements at the time of manufacture and be maintained in good condition to conform with safety factors for the materials and method of manufacture used.
- (5) Severability. If any provision of this chapter, or its application to any person, firm, corporation, or circumstance is held invalid under state (RCW) or national (Public Law) laws, the remainder of this chapter, or the application of the provision to other persons or circumstances isn't affected.
- (6) Variance and procedure. Recognizing that conditions may exist which don't exactly meet the literal requirements of this or other applicable Title 296 WAC standards, pursuant to RCW 49.17.080 and 49.17.090, the director of the department of labor and industries or his/her authorized representative may permit a variance when other means of providing an equivalent measure of protection are afforded. The specific requirements and procedures for variance application are contained in chapters 296-350 and 296-360 WAC. Application forms may be obtained from the assistant director for safety and health or from regional departmental offices.

[Statutory Authority: Chapter 49.17 RCW. 88-14-108 (Order 88-11), § 296-59-003, filed 7/6/88.]

WAC 296-59-005 Incorporation of other standards.

- (1) Lifts and tows shall be designed, installed, operated, and maintained in accordance with American National Standard Institute (ANSI) B77.1-1982, Standards for Passenger Tramways-Aerial Tramways and Lifts, Surface Lifts, and Tows-Safety Requirements.
- (2) Future revised editions of ANSI B77.1-1982 may be used for new installations or major modifications of existing installations, as recommended or approved by the equipment manufacturer or a qualified design engineer, except that, where specific provisions exist, variances shall be requested from the department.
- (3) Reserved.
- (4) The use of military type weapons for avalanche control shall comply with all requirements of the United States government and/or the military branch having jurisdiction. Compliance shall include qualification of employees, security requirements, and storage and handling of ammunition.

WAC 296-59-005 (Cont.)

- (5) The employer shall develop and maintain a chemical hazard communication program as required by WAC 296-800-170, which will provide information to all employees relative to hazardous chemicals or substances to which they are exposed, or may become exposed, in the course of their employment.
- (6) When employees perform activities such as construction work or logging, the WAC chapter governing the specific activity shall apply, e.g., chapter 296-155 or 296-54 WAC, et seq.

[Statutory Authority: RCW 49.17.010, .040, .050, and .060. 06-19-074 (Order 05-42), § 296-59-005, filed 09/19/06, effective 12/01/06. Statutory Authority: RCW 49.17.010, .040, .050. 01-11-038 (Order 99-36), § 296-59-005, filed 05/09/01, effective 09/01/01. Statutory Authority: Chapter 49.17 RCW. 94-16-145, § 296-59-005, filed 8/3/94, effective 9/12/94; 89-11-035 (Order 89-03), § 296-59-005, filed 5/15/89, effective 6/30/89; 88-14-108 (Order 88-11), § 296-59-005, filed 7/6/88.]

WAC 296-59-007 Definitions.

“**Act**” means the Washington Industrial Safety and Health Act of 1973, RCW 49.17.010 et seq.

“**Aerial work platform**” means any form of work platform, work chair, or workbasket designed to lift or carry workmen to an elevated work position.

“**ANSI**” means the American National Standards Institute.

“**Approved**” means approved by the director of the department of labor and industries except where this code requires approval by another specific body or jurisdiction authority.

“**ASME**” means the American Society of Mechanical Engineers.

“**Authorized person**” means a person approved or assigned by the employer to perform specific duties or to be at specific restricted locations.

“**Avalanche**” means the sliding or falling of a large amount of snow down a steep slope which has a destructive force due to its mass.

“**Belay**” means to provide an anchor for a safety line when a person is working in a position exposed to falling or sliding, the mountaineering term.

“**Designated**” means appointed or authorized by the highest management authority available at the site.

“**Department**” means the department of labor and industries, division of industrial safety and health, unless the context clearly indicates otherwise.

“**Director**” means the director of the department of labor and industries or his/her designated representative.

“**Hazard**” means that condition, potential or inherent, which might cause injury, death, or occupational disease.

“**Lift certificate to operate**” means an operating certificate issued by the Washington state parks and recreation commission pursuant to chapter 70.88 RCW subsequent to annual inspections as required by chapter 352-44 WAC.

“**N.E.C.**” means the National Electric Code, as published by either the National Fire Protection Association or ANSI.

“**Occupied building**” means a building regularly occupied in whole or in part as a habitation for human beings, or any church, schoolhouse, railroad station, store, or other building where people are accustomed to assemble.

“**Qualified**” means one who, by possession of a recognized degree, certificate, license, or professional standing, has successfully demonstrated the personal ability to solve or resolve problems relating to the subject matter, the work, or the project.

“**RCW**” means the Revised Code of Washington, legislative law.

“**ROPS**” means rollover protective structure.

“**S.A.E.**” means the society of automotive engineers.

“**Safety factor**” means the ratio of ultimate breaking strength of any member or piece of material or equipment to the actual working stress or safe load when in use.

WAC 296-59-007 (Cont.)

“**Shall**” indicates a mandatory requirement.

“**Should**” indicates a recommended practice.

“**WAC**” means the Washington Administrative Code.

“**WISHA**” means Washington industrial safety and health administration.

[Statutory Authority: RCW 49.17.010, .040, .050, and .060. 06-19-074 (Order 05-42), § 296-59-007, filed 09/19/06, effective 12/01/06. Statutory Authority: Chapter 49.17 RCW. 88-14-108 (Order 88-11), § 296-59-007, filed 7/6/88.]

WAC 296-59-010 Safe place standards. The safe place requirements of the safety and health core rules, WAC 296-800-110, shall be applicable within the scope of chapter 296-59 WAC.

[Statutory Authority: RCW 49.17.010, .040, .050. 01-11-038 (Order 99-36), § 296-59-010, filed 05/09/01, effective 09/01/01. Statutory Authority: Chapter 49.17 RCW. 88-14-108 (Order 88-11), § 296-59-010, filed 7/6/88.]

WAC 296-59-015 General requirements.

- (1) The use of any machinery, tool, material, or equipment which isn't in compliance with any applicable requirement of this chapter is prohibited. Such machine, tool, material, or equipment shall either be identified as unsafe by tagging or locking the controls to render them inoperable or shall be physically removed from its place of operation.
- (2) The employer shall permit only those employees qualified by training or experience to operate equipment and machinery.
- (3) Employees shall use safeguards provided for their protection.
- (4) Loose or ragged clothing, scarfs, or ties shall not be worn while working around moving machinery.
- (5) Workers shouldn't be assigned or permitted to occupy work locations directly under other workers. When such practice is unavoidable, all parties shall be made aware of the potential hazard and adequate protective measures shall be taken. When adequate protective measures aren't available, one party shall be moved to eliminate the potential exposure.
- (6) Employees shall report to their employers the existence of any unsafe equipment or method, or any other hazard which, to their knowledge, is unsafe. Where such unsafe equipment or method or other hazard exists in violation of this chapter it shall be corrected.
- (7) Housekeeping.
 - (a) All places of employment shall be kept clean to the extent that the nature of the work allows.
 - (b) The floor of every workroom shall be maintained so far as practicable in a dry condition. Where wet processes are used, drainage shall be maintained. Where necessary or appropriate, waterproof footgear shall be worn.
 - (c) To facilitate cleaning, every floor, working place, and passageway shall be kept free from protruding nails, splinters, loose boards, unnecessary holes and openings or other tripping hazards.
 - (d) Cleaning and sweeping shall be done in such a manner as to minimize the contamination of the air with dust and so far as is practical, shall be done outside of working hours.

- (8) Requirements for warning signs. Ski area operations which use any form of explosive device for avalanche control shall display warning, information placards and/or signs as found in chapter 296-52 WAC, Part G.

[Statutory Authority: RCW 49.17.010, .040, .050, and .060. 06-19-074 (Order 05-42), § 296-59-015, filed 09/19/06, effective 12/01/06. Statutory Authority: Chapter 49.17 RCW. 88-14-108 (Order 88-11), § 296-59-015, filed 7/6/88.]

WAC 296-59-020 Management's responsibility. The “safe work environment” section of the safety and health core rules, WAC 296-800-110, shall be applicable within the scope of chapter 296-59 WAC.

[Statutory Authority: RCW 49.17.010, .040, .050. 01-11-038 (Order 99-36), § 296-59-020, filed 05/09/01, effective 09/01/01. Statutory Authority: Chapter 49.17 RCW. 88-14-108 (Order 88-11), § 296-59-020, filed 7/6/88.]

WAC 296-59-025 Employee's responsibility. The “employee responsibilities” section of the safety and health core rules, WAC 296-800-120, shall be applicable within the scope of chapter 296-59 WAC.

[Statutory Authority: RCW 49.17.010, .040, .050. 01-11-038 (Order 99-36), § 296-59-025, filed 05/09/01, effective 09/01/01. Statutory Authority: Chapter 49.17 RCW. 88-14-108 (Order 88-11), § 296-59-025, filed 7/6/88.]

WAC 296-59-027 Work activities which include skiing. Management shall develop a written safety program for all employees whose job duties include skiing. The program shall include but isn't limited to the following:

- (1) The skiing ability and physical condition of individuals shall be considered when determining individual job assignments;
- (2) The ski equipment used shall be appropriate for the individual when performing any given job assignment;
- (3) The condition of all ski equipment shall be checked by a qualified individual at the beginning of each ski season;
- (4) Employees shall be instructed not to use ski equipment until it has been checked and approved;
- (5) Employees shall be instructed to ski within their ability and in control at all times;
- (6) Employees shall be required to check all ski equipment, including adjustments, before starting work each day;
- (7) Employees shall be instructed not to use ski equipment which is defective or out of adjustment.

[Statutory Authority: Chapter 49.17 RCW. 88-14-108 (Order 88-11), § 296-59-027, filed 7/6/88.]

WAC 296-59-030 Safety bulletin board. The “safety bulletin board” requirements of the safety and health core rules, WAC 296-800-190, shall be applicable within the scope of chapter 296-59 WAC.

[Statutory Authority: RCW 49.17.010, .040, .050. 01-11-038 (Order 99-36), § 296-59-030, filed 05/09/01, effective 09/01/01. Statutory Authority: Chapter 49.17 RCW. 88-14-108 (Order 88-11), § 296-59-030, filed 7/6/88.]

WAC 296-59-035 First-aid. The first-aid provisions of the safety and health core rules, WAC 296-800-150 apply within the scope of chapter 296-59 WAC.

[Statutory Authority: RCW 49.17.010, .040, .050. 01-11-038 (Order 99-36), § 296-59-035, filed 05/09/01, effective 09/01/01. Statutory Authority: RCW 49.17.010, .040, .050. 00-01-038 (Order 99-08), § 296-59-035, filed 12/07/99, effective 02/01/2000. Statutory Authority: Chapter 49.17 RCW. 88-14-108 (Order 88-11), § 296-59-035, filed 7/6/88.]

WAC 296-59-050 Personal protective equipment, general requirements.

- (1) Application.
 - (a) Protective equipment, including personal protective equipment for eyes, face, head, and extremities, protective clothing, respiratory devices, and protective shields and barriers, shall be provided at no cost to the employee, used, and maintained in a sanitary and reliable condition wherever it is indicated by reason of hazards of processes or environment, chemical hazards, radiological hazards, or mechanical irritants encountered in a manner capable of causing injury or impairment in the function of any part of the body through absorption, inhalation, or physical contact.
 - (b) Employee-owned equipment. Where employees provide their own protective equipment, the employer shall be responsible to assure its adequacy, including proper maintenance, and sanitation of such equipment.
 - (c) Design, construction, testing, and use of personal protective equipment shall comply with the requirements of the safety and health core rules, WAC 296-800-160; the Occupational health standards--Safety standards for carcinogens, chapter 296-62 WAC; or the currently applicable ANSI standard.
- (2) Eye and face protection. Eye and face protective equipment shall be provided and worn where there is exposure in the work process or environment to hazard of injury, which can be prevented by such equipment.

WAC 296-59-050 (Cont.)

- (3) Occupational head protection. Employees working in areas where there is a possible danger of head injury from impact, or from falling or flying objects, or from electrical shock and burns, shall be protected by protective helmets, i.e., a lift operator wouldn't be required to use a hardhat while operating the lift. However, if that same person is assisting with maintenance operations and is working under a tower where overhead work is being done, that operator would now be required to wear an approved helmet.
 - (a) Helmets for the protection of employees against impact and/or penetration of falling and flying objects shall meet the specifications contained in American National Standards Institute, Z89.1-1986, Safety Requirements for Industrial Head Protection.
 - (b) Helmets for the head protection of employees exposed to high voltage electrical shock and burns shall meet the specifications contained in American National Standards Institute, Z89.2-1971, Safety Requirements for Industrial Protective Helmets for Electrical Workers, Class B.
 - (c) Approved head protection shall be worn by operators of snowmobiles and other mobile oversnow equipment which isn't equipped with a rigid metal operator's cab.
- (4) Occupational foot protection.
 - (a) Substantial footwear appropriate for the work conditions encountered shall be worn by all employees.
 - (b) Where the job assignment includes exposure to slipping hazards, soles and heels of footwear shall be of such material and design as to reduce the hazard of slipping.
- (5) Safety belts, lifelines, lanyards, and nets.
 - (a) Safety belts, lifelines, and lanyards which meet the requirements of ANSI A10.14 shall be provided and used whenever employees are working in locations which expose them to a fall of more than ten feet. The particular work location and application shall dictate which type of belt or harness and length of lanyard is used.
 - (b) Lifelines shall be secured to an anchorage or structural member capable of supporting a minimum dead weight of five thousand four hundred pounds.
 - (c) Lifelines used on rock scaling applications or in areas where the lifeline may be subjected to cutting or abrasion shall be a minimum of seven-eighths inch wire core manila rope or equivalent. For all other lifeline applications, three-fourths inch manila rope or equivalent with a minimum break strength of five thousand four hundred pounds may be used.
 - (d) Each safety belt lanyard shall be a minimum of one-half inch nylon, or equivalent, with a minimum of five thousand four hundred pounds breaking strength.
 - (e) Employees won't be required to wear a safety belt and lanyard while riding on a standard lift chair while seated in the normal riding position.
 - (f) Safety nets meeting the requirements of ANSI A10.11 shall be used when other acceptable forms of fall protection aren't useable. When used, safety nets shall extend a minimum of eight feet beyond the edge offering exposure, shall be hung with sufficient clearance to prevent user's contact with surfaces or objects below, and shall not be more than twenty-five feet below the fall exposure edge.

[Statutory Authority: RCW 49.17.010, .040, .050, 01-11-038 (Order 99-36), § 296-59-050, filed 05/09/01, effective 09/01/01. Statutory Authority: Chapter 49.17 RCW, 88-14-108 (Order 88-11), § 296-59-050, filed 7/6/88.]

WAC 296-59-055 Lockout requirements.

- (1) Each employer shall develop a formal written policy and procedure for lockout requirements. The policy shall embody the principles of subsection (2) of this section and shall clearly state that the procedures must be applied in all instances.

WAC 296-59-055 (Cont.)

- (a) The lockout policy shall be posted on all required employee bulletin boards.
 - (b) The lockout policy and procedures shall be made a part of new employee orientation and employee training programs.
 - (c) Supervisors and crew leadpersons shall assure compliance with the published policy and procedures in all instances.
- (2) Whenever the unexpected start-up of machinery, the energizing of electrical circuits, the flow of material in piping systems, or the removal of guards would endanger workers, such exposure shall be prevented by deactivating and locking out the controls as required by this section.
- (3) Equipment requirements.
- (a) The employer shall provide and each employee shall use as many padlocks, tags, chains, or devices as are necessary to implement these requirements.
 - (b) Provisions shall be made whereby the source of power or exposure can be locked out in accordance with the requirements of this section.
 - (c) On electrically powered equipment, “stop/start” control switches shall not be used as lockout switches. Lockout switches must be the primary circuit disconnects and must adequately separate both the power source and any auxiliary power unit from the prime mover so that accidental start-up of the equipment being locked out is precluded.
 - (d) Keyed-alike locks, which all open with identical keys, shall not be issued as personal lockout locks.
- (4) Training requirements.
- (a) Each person who will be given authority to implement these requirements shall first be thoroughly trained in the requirements and procedures.
 - (b) Before being given authority to deactivate and lockout a particular system or piece of equipment, authorized personnel shall be made fully aware of all power sources and/or material entry sources which may offer exposure.
 - (c) Checklists shall be used to implement effective lockout procedures for complex systems or equipment.
 - (i) Complex is identified as those systems or equipment which require the locking out of four or more controls to assure isolation or which have controls remote from the immediate work area.
 - (ii) Checklists shall identify all controls necessary to achieve isolation at the intended worksite(s).
 - (iii) Checklists shall provide a space after each listed control to be used for the identity of the person(s) who performed the lockout and required post-lockout tests of each control.
 - (iv) Checklists shall be prepared by qualified personnel and approved by the responsible area supervisor before each use.
- (5) Control procedure.
- (a) Each person who could be exposed to the hazard shall apply a personal padlock on each control mechanism. Padlocks shall be applied in such a manner as to physically block the controls from being moved into the operating position. Each lock shall be personally identified or an information tag identifying the owner shall be attached to the lock.

WAC 296-59-055 (Cont.)

- (b) Padlocks used in lockout procedures may only be removed by the person identified on the lock, except, when it is positively determined that the owner/user of the lock has left the premises without removing a lock, the job supervisor may remove the lock in accordance with a specific procedure formulated by the local plant labor management safety committee or approved by the department.
- (6) Testing after lockout or tagout. After tagging or locking out equipment, a test shall be conducted to ascertain that the equipment has been made inoperative or the flow of material has been positively stopped. Precautions shall be taken to ascertain that persons won't be subjected to any hazard while conducting the test if the power source or flow of material isn't shut off.
- (7) Temporary or alternate power to be avoided. Whenever possible, temporary or alternate sources of power to the equipment being worked on shall be avoided. If the use of such power is necessary, all affected employees shall be informed and the source of temporary or alternate power shall be identified.
- (8) Where tags or signs are required to implement the lockout and control procedures, the tag and attachment device shall be constructed of such material that it won't be likely to deteriorate in the environment that it will be subjected to.
- (9) Provisional exception. Electrical lighting and instrument circuits of two hundred forty volts or less on single phase systems or two hundred seventy-seven volts on three-phase systems may be exempted from the lockout requirements of subsection (5)(a) of this section provided that:
 - (a) An information tag meeting the requirements of subsection (8) of this section is used in lieu of a padlock.
 - (b) The information tag shall be placed on the switch or switch cover handle in such a manner as to easily identify the deactivated switchgear.
- (10) Deactivating piping systems.
 - (a) Hazardous material systems are defined as: Gaseous systems that are operated at more than two hundred psig; systems containing any liquid at more than five hundred psig; systems containing any material at more than 130°F; systems containing material which is chemically hazardous as defined by NFPA 704 M Class 3 and 4; systems containing material classified as flammable or explosive as defined in NFPA Class I.
 - (b) Lockout of piping systems shall provide isolation to the worksite, including backflow where such potential exists and where the system is classified as a hazardous material system. The required method shall be applied based on the content of the system as specified below:
 - (i) Nonhazardous systems shall be deactivated by locking out either the pump or a single valve.
 - (ii) Hazardous material systems shall be deactivated by one of the following methods:
 - (A) Locking out both the pump and one valve between the pump and the worksite;
 - (B) Locking out two valves between the hazard source and the worksite;
 - (C) Installing and locking out a blank flange between the hazard source and worksite.

Exception: Aerial tramways and lifts, surface lifts and tows. It is recognized that some inspection, testing, running adjustments, and maintenance tasks can't be accomplished on this equipment while using standard lockout procedures, particularly when using a work platform suspended from the haulrope. Management of each ski area shall therefore develop a specific written procedure to be used in any instance where any potentially exposed personnel can't personally lock the controls. The procedure for each area shall meet the following minimum requirements:

- (I) The controls shall be attended by a qualified operator at all times when personnel are in potentially exposed work positions and the controls aren't padlocked out.

WAC 296-59-055 (Cont.)

- (II) Direct communication capability between the control operator and remote work crew shall be maintained at all times.
- (III) All personnel involved shall be thoroughly trained in the exact procedures to be followed.
- (IV) Extension tools which minimize personnel exposure shall be used where possible.
- (V) The equipment shall be operated at the slowest speed possible consistent with the task at hand.
- (VI) This exception shall not be used by more than one workcrew at more than one remote location on any single piece of equipment or system.
- (VII) This exception is limited to work on the haulrope, towers, and replacing bullwheel liners. For all other work on the bullwheels or drive operations, the master disconnect shall be deactivated and locked out.

Note: See Appendix I for illustrative example.

[Statutory Authority: Chapter 49.17 RCW. 88-14-108 (Order 88-11), § 296-59-055, filed 7/6/88.]

WAC 296-59-060 Vessel or confined area requirements. The requirements of WAC 296-62-145 through 296-62-14529, general occupational health standards for permit - required confined spaces, shall be applicable within the scope of chapter 296-59 WAC.

[Statutory Authority: RCW 49.17.010, .040, .050. 01-11-038 (Order 99-36), § 296-59-060, filed 1/18/95, effective 3/1/95; 88-14-108 (Order 88-11), § 296-59-060, filed 7/6/88.]

WAC 296-59-065 Fire protection and ignition sources. The requirements of WAC 296-24-585 and 296-800-300, et seq., relating to fire protection requirements, shall be applicable within the scope of chapter 296-59 WAC.

[Statutory Authority: RCW 49.17.010, .040, .050. 01-11-038 (Order 99-36), § 296-59-065, filed 05/09/01, effective 09/01/01. Statutory Authority: Chapter 49.17 RCW. 88-14-108 (Order 88-11), § 296-59-065, filed 7/6/88.]

WAC 296-59-070 Illumination.

- (1) Sufficient illumination required. All areas shall be sufficiently illuminated in order that persons in the area can safely perform their assigned duties. The recommended levels of illumination specified in the safety and health core rules, WAC 296-800-210, shall be followed. When areas aren't specifically referred to in chapter 296-800 WAC and the adequacy of illumination for the area or task performed is questionable, a determination of the amount of illumination needed may be made by the division of industrial safety and health.
- (2) Emergency or secondary lighting system required.
 - (a) There shall be an emergency or secondary lighting system which can be actuated immediately upon failure of the normal power supply system. The emergency or secondary lighting system shall provide illumination in the following areas:
 - (i) Wherever it is necessary for workers to remain at their machine or station to shut down equipment in case of power failure;
 - (ii) At stairways and passageways or aiseways used by workers as an emergency exit in case of power failure;
 - (iii) In all plant first-aid and/or medical facilities;
 - (iv) In emergency power and control room, i.e., in emergency generator rooms unless arranged to start automatically in the event of power failure, or on ski lift motor drive rooms where it would be necessary for employees to switch on the emergency drive system during night skiing.

WAC 296-59-070 (Cont.)

- (b) Emergency lighting facilities shall be checked at least every thirty days for mechanical defects. Defective equipment shall be given priority for repair schedule.

(3) Extension cord type lights. All extension cord type lights shall be provided with proper guards.
[Statutory Authority: RCW 49.17.010, .040, .050. 01-11-038 (Order 99-36), § 296-59-070, filed 05/09/01, effective 09/01/01. Statutory Authority: Chapter 49.17 RCW. 88-14-108 (Order 88-11), § 296-59-070, filed 7/6/88.]

WAC 296-59-075 Electrical equipment and distribution.

- (1) National Electrical Code to prevail. All electrical installations and electrical utilization equipment shall comply with the National Electrical Code requirements.

Exception: In instances where (N.E.C.) conflicts with ANSI B77.1 with respect to tramways, surface lifts, or tows, ANSI B77.1 shall prevail.

- (2) Authorized personnel to do electrical work. Only those persons who are qualified to do the work assigned and are authorized by the employer shall be allowed to perform electrical work on any electrical equipment or wiring installations.
- (3) High voltage areas to be guarded. Motor rooms, switch panel rooms, or other areas where persons may come in contact with high voltages shall be fenced off or be enclosed in a separate area. The gate, door, or access to such area shall be posted with a notice stating that only authorized persons are allowed in the area.
- (4) Control panels. In areas where mobile equipment operates, floor stand panels shall be protected from being struck by moving equipment. Start or run handles and buttons shall be protected from accidental actuation.
- (5) Switches or control devices. Switches, circuit breakers, or other control devices shall be so located that they are readily accessible for activation or deactivation and shall be marked to indicate their function or machine which they control. The positions of ON and OFF shall be marked or indicated and provision shall be made for locking out the circuit.
- (6) Starting requirements for electrically driven equipment after power failure. Electrically driven equipment shall be so designed that it won't automatically start upon restoration of power after a power failure if it will create a hazard to personnel.
- (7) Posting equipment automatically activated or remotely controlled. Equipment which is automatically activated or remotely controlled shall be posted, warning persons that machine may start automatically if it will create a hazard to personnel.

[Statutory Authority: Chapter 49.17 RCW. 88-14-108 (Order 88-11), § 296-59-075, filed 7/6/88.]

WAC 296-59-080 Installation, inspection, and maintenance of pipes, piping systems, and hoses.

- (1) Definitions applicable to this section.
- (a) **"Hazardous material system"** is any system within the following classifications:
- (i) **"Flammable or explosive"** - any system containing materials which are hazardous because they are easily ignited and create a fire or explosion hazard, defined by NFPA as Class I liquids;
- (ii) **"Chemically active or toxic"** - any system containing material which offers corrosion or toxic hazard in itself or can be productive of harmful gases upon release, defined by NFPA 704M as Class 3 and 4 materials;
- (iii) **"Thermally hazardous"** - any system above 130°F which exposes persons to potential thermal burns;
- (iv) **"Pressurized"** - any gaseous system above two hundred psig or liquid system above five hundred psig.

WAC 296-59-080 (Cont.)

- (b) **“Piping system”** - any fixed piping, either rigid pipe or flexible hose, including all fittings and valves, in either permanent or temporary application.
- (2) Design and installation. All new piping systems intended to be used in hazardous material service shall be designed and installed in accordance with applicable provisions of the ASME Code for Pressure Piping or in accordance with applicable provisions of ANSI B31.1 through B31.8. The referenced edition in effect at the time of installation shall be utilized.
- Note: Both referenced standard have identical requirements*
- (3) Inspection and maintenance.
- (a) Management shall develop a formal program of inspections for all hazardous material piping systems. The program shall be based on sound maintenance engineering principles and shall demonstrate due consideration for the manufacturing specifications of the pipe, hose, valves, and fittings, the ambient environment of the installation and the corrosive or abrasive effect of the material handled within the system.
 - (b) Type and frequency of tests and/or inspections and selection of inspection sites shall be adequate to give indications that minimum safe design operating tolerances are maintained. The tests may include visual and nondestructive methods.
 - (c) All employers shall submit their formal program of initial and ongoing inspections to the department for approval within one year after the effective date of this requirement.
 - (d) All existing hazardous material systems shall be inspected to the criteria of this section prior to two years after effective date, or in accordance with a schedule approved by the department.
- (4) Inspection records.
- (a) Results of inspections and/or tests shall be maintained as a record for each system.
 - (b) Past records may be discarded provided the current inspection report and the immediate preceding two reports are maintained.
 - (c) When a system is replaced, a new record shall be established and all past records may be discarded.
 - (d) The records for each system shall be made available for review by the department upon request.
 - (e) The employer may omit the inspection requirements for portions of existing systems that are buried or enclosed in permanent structures in such a manner as to prevent exposure to employees even in the event of a failure.
- (5) Systems or sections of systems found to be below the minimum design criteria requirements for the current service shall be repaired or replaced with component parts and methods which equal the requirements for new installations.
- (6) Identification of piping systems.
- (a) Pipes containing hazardous materials shall be identified. It is recommended that USAS A13.1 “Scheme for Identification of Piping Systems” be followed.
 - (b) Positive identification of piping system content shall be identified by lettered legend giving the name of the content in full or abbreviated form, or a commonly used identification system. Such identification shall be made and maintained at suitable intervals and at valves, fittings, and on both sides of walls or floors. Arrows may be used to indicate the direction of flow. Where it is desirable or necessary to give supplementary information such as hazard of use of the piping system content, this may be done by additional legend or by color applied to the entire piping system or as colored bands. Legends may be placed on colored bands.

WAC 296-59-080 (Cont.)

Examples of legends which may give both positive identification and supplementary information regarding hazards or use are:

Ammonia	Hazardous liquid or gas
Chlorine	Hazardous liquid or gas
Liquid caustic	Hazardous liquid
Sulphuric acid	Hazardous liquid
Natural gas	Flammable/explosive gas

Note: *Manual L-1, published by Chemical Manufacturers Association, Inc., is a valuable guide in respect to supplementary legend.*

- (c) When color, applied to the entire piping system or as colored bands, is used to give supplementary information it should conform to the following:

Classification	Predominant Color
F-Fire protection equipment	Red
D-Dangerous materials	Yellow (or orange)
S-Safe materials	Green (or the achromatic colors, white, black, gray, or aluminum)
And, when required, P-Protective materials	Bright blue

- (d) Legend boards showing the color and identification scheme in use shall be prominently displayed at each plant. They shall be located so that employees who may be exposed to hazardous material piping systems will have a frequent reminder of the identification program.
- (e) All employees who work in the area of hazardous material piping systems shall be given training in the color and identification scheme in use.

[Statutory Authority: Chapter 49.17 RCW. 88-14-108 (Order 88-11), § 296-59-080, filed 7/6/88.]

WAC 296-59-085 Scaffolds, construction, use, and maintenance.

- (1) Whenever work must be performed at a height which can't be reached from the floor or permanent platform and where it wouldn't be a safe practice to use a ladder, a properly constructed scaffold shall be provided and used.
- (2) Scaffolds shall be constructed and used in compliance with Scaffolds, chapter 296-874, WAC.
[Statutory Authority: RCW 49.17.010, .040, .050. 01-11-038 (Order 99-36), § 296-59-085, filed 05/09/01, effective 09/01/01. Statutory Authority: Chapter 49.17 RCW. 88-14-108 (Order 88-11), § 296-59-085, filed 7/6/88.]

WAC 296-59-090 Mobile equipment and lift trucks.

- (1) Mobile equipment shall be designed, constructed, maintained, and used in accordance with this section and appropriate ANSI and/or SAE requirements.
- (2) Operator training.
- (a) Methods shall be devised by management to train personnel in the safe operation of mobile equipment.
- (b) Training programs for all mobile equipment shall include the manufacturer's operating instructions when such instructions are available.
- (c) Only trained and authorized operators shall be permitted to operate such vehicles.
- (3) Special duties of operator. Special duties of the operator of a power-driven vehicle shall include the following:
- (a) Test brakes, steering gear, lights, horns, warning devices, clutches, etc., before operating vehicle;

WAC 296-59-090 (Cont.)

- (b) Not move a vehicle while an unauthorized rider is on the vehicle;
 - (c) Slow down and sound horn upon approaching blind corners or other places where vision or clearance is limited;
 - (d) Comply with all speed and traffic regulations and other applicable rules;
 - (e) Have the vehicle being operated under control at all times so that he can safely stop the vehicle in case of emergency; and
 - (f) Keep the load on the uphill side when driving a forklift vehicle on a grade.
- (4) Operator to be in proper position. Control levers of lift trucks, front end loaders, or similar types of equipment shall not be operated except when the operator is in his proper operating position.
- (5) Raised equipment to be blocked. Employees shall not work below the raised bed of a dump truck, raised buckets of front end loaders, raised blades of tractors or in similar positions without blocking the equipment in a manner that will prevent it from falling. When working under equipment suspended by use of jacks, safety stands or blocking shall be used in conjunction with the jack.
- (6) Precautions to be taken while inflating tire. Unmounted split rim wheels shall be placed in a safety cage or other device shall be used which will prevent a split rim from striking the worker if it should dislodge while the tire is being inflated.
- (7) Reporting suspected defects. If, in the opinion of the operator, a power-driven vehicle is unsafe, the operator shall report the suspected defect immediately to the person in charge. Any defect which would make the vehicle unsafe to operate under existing conditions shall be cause for immediate removal from service. The vehicle shall not be put back into use until it has been made safe.
- (8) Safe speed. Vehicles shall not be driven faster than a safe speed compatible with existing conditions.
- (9) Unobstructed view.
- (a) Vehicle operators shall have a reasonably unobstructed view of the direction of travel. Where this isn't possible, the operator shall be directed by a person or by a safe guidance means or device.
 - (b) Where practical, mirrors shall be installed at blind corners or intersections which will allow operators to observe oncoming traffic.
 - (c) It is recommended that vehicles operating in congested areas be provided with an automatic audible or visual alarm system.
- (10) Passengers to ride properly.
- (a) Passengers shall not be permitted to ride with legs or arms extending outside the running lines of the cab, FOPS, or ROPS of any vehicle.
 - (b) Passengers on mobile oversnow equipment shall ride within the cab unless exterior seating is provided. The exterior seating may include the cargo bed provided that the bed is equipped with sideboards and a tailgate at least ten inches high. If passengers are permitted to stand in the bed, adequate handholds shall be provided.
 - (c) The number of passengers and seating arrangements within the cab on any mobile equipment shall not interfere with the operator's ability to safely operate the equipment.
 - (d) Exterior passengers shall not be permitted on mobile oversnow equipment which has snow grooming equipment mounted on the bed or when the machine is towing any kind of equipment, sleds, etc.
 - (e) Operators shall use good judgment with respect to speed and terrain when carrying exterior passengers.

WAC 296-59-090 (Cont.)

- (11) Horns and lights.
 - (a) Every vehicle shall be provided with an operable horn distinguishable above the surrounding noise level.
 - (b) Any vehicle required to travel away from an illuminated area shall be equipped with a light or lights which adequately illuminate the direction of travel.
- (12) Brakes on power-driven vehicles. Vehicles shall be equipped with brakes and devices which will hold a parked vehicle with load on any grade on which it may be used. The brakes and parking devices shall be kept in proper operating condition at all times.
- (13) Cleaning vehicles. All vehicles shall be kept free of excessive accumulations of dust and grease which may present a hazard.
- (14) Lifting capacity of vehicle to be observed. At no time shall a load in excess of the manufacturer's maximum lifting capacity rating be lifted or carried. Such lifting capacity may only be altered with the approval of the equipment manufacturer or a qualified design engineer.
- (15) Posting rated capacity. The maximum rated lifting capacity of all lift trucks shall at all times be posted on the vehicle in such a manner that it is readily visible to the operator.
- (16) Carrying loose material. Lift trucks shall not be used to carry loose loads of pipe, steel, iron, lumber, palletized material, rolls of paper, or barrels unless adequate clearance is provided and the loads are stabilized.
- (17) Position of lift forks or clamps. The forks or clamps of lift trucks shall be kept as low as possible while the vehicle is moving. They shall be lowered to the ground or floor when the vehicle is parked.
- (18) Walking under loads prohibited. No person shall be allowed under the raised load of a lift truck, backhoe, or front end loader.
- (19) Hoisting of personnel on vehicle forks prohibited. Personnel shall not be hoisted by standing directly on the forks of vehicles.
- (20) Using forklifts as elevated work platforms. A platform or structure built specifically for hoisting persons may be used providing the following requirements are met:
 - (a) The structure must be securely attached to the forks and shall have standard guardrails and toeboards installed on all sides;
 - (b) The hydraulic system shall be so designed that the lift mechanism won't drop faster than one hundred thirty-five feet per minute in the event of a failure in any part of the system. Forklifts used for elevating work platforms shall be identified that they are so designed;
 - (c) A safety strap shall be installed or the control lever shall be locked to prevent the boom from tilting;
 - (d) An operator shall attend the lift equipment while workers are on the platform;
 - (e) The operator shall be in the normal operating position while raising or lowering the platform. A qualified operator shall remain in attendance whenever an employee is on the work platform;
 - (f) The vehicle shall not travel from point to point while workers are on the platform except that inching or maneuvering at very slow speed is permissible; and
 - (g) The area between workers on the platform and the mast shall be adequately guarded to prevent contact with chains or other shear points.
- (21) Overhead guards on lift trucks. All lift trucks shall be equipped with an overhead guard constructed and installed to conform to USAS B56.1-1969 "Safety Code for Powered Industrial Trucks." This guard may be removed only when it can't be used due to the nature of the work being performed in which case loads shall be maintained so as not to create a hazard to the operator.

WAC 296-59-090 (Cont.)

- (22) Protection from exhaust system. Any exhaust system which might be exposed to contact shall be properly insulated or isolated to protect personnel. Exhaust systems on lift trucks and jitneys shall be constructed to discharge either within twenty inches from the floor or eighty-four inches or more above the floor. The exhausted gases shall be directed away from the operator. The equipment shall be designed in such a manner that the operator won't be exposed to the fumes.
- (23) Emergency exit from mobile equipment. Mobile equipment with an enclosed cab shall be provided with an escape hatch or other method of exit in case the regular exit can't be used.
- (24) Vehicle wheels chocked. When driving mobile equipment onto the bed of a vehicle, the wheels of the vehicle shall be chocked.
- (25) Prevent trailer from tipping. Suitable methods shall be used or devices installed which will prevent the trailer from tipping while being loaded or unloaded.
- (26) Refueling. Gasoline or LPG engines shall be shut off during refueling.
- (27) Close valve on LPG container. Whenever vehicles using LP gas as a fuel are parked overnight or stored for extended periods of time indoors, with the fuel container in place, the service valve of the fuel container shall be closed.
- (28) LPG tanks. LPG vehicle fuel tanks shall be installed and protected in a manner which will minimize the possibility of damage to the tank.
- (29) Inspecting and testing of LPG containers. LPG containers shall be inspected and tested as required by chapter 296-24 WAC.
- (30) Spinners on steering wheels. The use of spinners on steering wheels shall be prohibited unless an antikick device is installed or the equipment has a hydraulic steering system.
- (31) The requirements of chapter 296-817 WAC, Hearing loss prevention (noise), apply to mobile equipment operation.

[Statutory Authority: RCW 49.17.010, .040, .050, and .060. 03-11-060 (Order 02-16), § 296-59-090, filed 05/19/03, effective 08/01/03. Statutory Authority: Chapter 49.17 RCW. 88-14-108 (Order 88-11), § 296-59-090, filed 7/6/88.]

WAC 296-59-095 Requirements for cranes and hoists-General safety and health standards to prevail. All applicable rules for design, construction, maintenance, operation, and testing of cranes and hoists contained in the General safety and health standards, chapter 296-24 WAC, shall be met.

[Statutory Authority: Chapter 49.17 RCW. 88-14-108 (Order 88-11), § 296-59-095, filed 7/6/88.]

WAC 296-59-115 Ski lift facilities and structures.

- (1) Existing ski lift facilities and structures shall not be required to be retrofitted with standard construction work platforms, walkways, stairs or guardrails on exterior surfaces when such features would add significantly to snow loading considerations. When such standard protective features are omitted, alternative personal protective measures shall be used where possible. Examples include but aren't limited to: Safety belt and lanyard, ladder climbing safety devices, temporary work platforms or scaffolds, temporary or removable handrails, guardrails, or walkways.
- (2) Snow removal.
 - (a) During the operating season, standard guardrails which would interfere with snow removal may be omitted in areas where it can be anticipated that frequent snow removal will be necessary to maintain operability of ski lift apparatus. Examples could include but aren't limited to the motor house roof or loading and unloading areas.
 - (b) Personnel barricades, signs, or other devices shall be used to deflect traffic or warn personnel of existing fall hazards.

WAC 296-59-115 (Cont.)

- (3) All ski lift towers installed after the effective date of this standard shall be equipped with permanent ladders or steps which meet the following minimum requirements:
- (a) The minimum design live load shall be a single concentrated load of two hundred pounds.
 - (b) The number and position of additional concentrated live load units of two hundred pounds each as determined from anticipated usage of the ladder shall be considered in the design.
 - (c) The live loads imposed by persons occupying the ladder shall be considered to be concentrated at such points as will cause the maximum stress in the structural member being considered.
 - (d) The weight of the ladder and attached appurtenances together with the live load shall be considered in the design of rails and fastenings.
 - (e) All rungs shall have a minimum diameter of three-fourths inch.
 - (f) The distance between rungs on steps shall not exceed twelve inches and shall be uniform throughout the ladder length. The top rung shall be located at the level of the landing or equipment served by the ladder.
 - (g) The minimum clear length of rungs or steps shall be sixteen inches on new installations.
 - (h) Rungs, cleats, and steps shall be free of sharp edges, burrs, or projections which may be a hazard.
 - (i) The rungs of an individual-rung ladder shall be so designed that the foot can't slide off the end. (A suggested design is shown in Figure D-1, at the end of this section.)
 - (j) Side rails which might be used as a climbing aid shall be of such cross sections as to afford adequate gripping surface without sharp edges or burrs.
 - (k) Fastenings. Fastenings shall be an integral part of fixed ladder design.
 - (l) All splices made by whatever means shall meet design requirements as noted in (a) of this subsection. All splices and connections shall have smooth transition with original members and with no sharp or extensive projections.
 - (m) Adequate means shall be employed to protect dissimilar metals from electrolytic action when such metals are joined.
 - (n) Welding. All welding shall be in accordance with the "Code for Welding in Building Construction" (AWS D1.0-1966).
 - (o) Protection from deterioration. Metal ladders and appurtenances shall be painted or otherwise treated to resist corrosion and rusting when location demands.
- (4) Installation and clearance.
- (a) Pitch.
 - (i) The preferred pitch of fixed ladders is between the range of seventy-five degrees and ninety degrees with the horizontal (Figure D-4).
 - (ii) Substandard pitch. Fixed ladders shall be considered as substandard if they are installed within the substandard pitch range of forty-five and seventy-five degrees with the horizontal. Substandard fixed ladders are permitted only where it is found necessary to meet conditions of installation. This substandard pitch range is considered as a critical range to be avoided, if possible.
 - (iii) Pitch greater than ninety degrees. Ladders having a pitch in excess of ninety degrees with the horizontal are prohibited.

WAC 296-59-115 (Cont.)

- (b) Clearances.
 - (i) The perpendicular distance from the centerline of the rungs to the nearest permanent object on the climbing side of the ladder shall be thirty-six inches for a pitch of seventy-six degrees, and thirty inches for a pitch of ninety degrees (Figure D-2), with minimum clearances for intermediate pitches varying between these two limits in proportion to the slope.
 - (ii) A clear width of at least fifteen inches shall be provided each way from the centerline of the ladder in the climbing space.
 - (iii) The side rails of through or side-step ladder extensions shall extend three and one-half feet above parapets and landings.
 - (A) For through ladder extensions, the rungs shall be omitted from the extension and shall haven't less than eighteen nor more than twenty-four inches clearance between rails.
 - (B) For side-step or offset fixed ladder sections, at landings, the side rails and rungs shall be carried to the next regular rung beyond or above the three and one-half feet minimum.
 - (iv) Grab bars shall be spaced by a continuation of the rung spacing when they are located in the horizontal position. Vertical grab bars shall have the same spacing as the ladder side rails. Grab bar diameters shall be the equivalent of the round-rung diameters.
 - (v) Clearance in back of ladder. The distance from the centerline of rungs, cleats, or steps to the nearest permanent object in back of the ladder shall be not less than seven inches, except that when unavoidable obstructions are encountered, minimum clearances as shown in Figure D-3 shall be provided.
 - (vi) Clearance in back of grab bar. The distance from the centerline of the grab bar to the nearest permanent object in back of the grab bars shall be not less than four inches. Grab bars shall not protrude on the climbing side beyond the rungs of the ladder which they serve.
- (c) The step-across distance from the nearest edge of a ladder to the nearest edge of the equipment or structure shall be not more than twelve inches, or less than two and one-half inches. However, the step-across distance may be as much as twenty inches provided:
 - (i) The climber is wearing a safety belt and lanyard; and
 - (ii) The lanyard is attached to the tower structure before the climber steps off the ladder.
- (5) Ski lift towers aren't required to be equipped with ladder cages, platforms or landings.
- (6) Maintenance and use.
 - (a) All ladders shall be maintained in a safe condition. All ladders shall be inspected regularly, with the intervals between inspections being determined by use and exposure.
 - (b) When ascending or descending, the climber must face the ladder.
 - (c) Personnel shall not ascend or descend ladders while carrying tools or materials which could interfere with the free use of both hands.
- (7) Personnel shall be provided with and shall use ladder safety devices or safety belt and lanyard whenever feasible.
- (8) Personnel shall not place mobile equipment or personal equipment such as skis, ski poles, or large tools within the falling radius of the lift tower while climbing or working on the lift tower.

- (9) Ski lift towers and terminals aren't required to be equipped with sheave guards on the haulrope wheels.

WAC 296-59-115 (Cont.)

- (10) Ski lift towers aren't required to be equipped with work platforms.
- (11) Personnel shall use personal protective equipment such as a safety belt and lanyard when working at unprotected elevated locations. Exception to this requirement shall only be permitted for emergency rescue or emergency inspection if a safety belt and lanyard isn't immediately available. Required personal protective equipment shall be made available as quickly as possible.
- (12) When fixed ladders on towers don't reach all the way down to the ground or snow level, a specifically designed and constructed portable ladder shall be used for access to and from the fixed ladder. Portable ladders shall be constructed and maintained to the following requirements:
 - (a) The portable ladder shall be constructed in accordance with applicable provisions of subsection (3) of this section.
 - (b) The portable ladder shall be constructed with a minimum of two attachment hooks near the top to be utilized for securing the portable ladder onto the fixed ladder.
 - (c) The attachment hooks shall be installed to support the portable ladder near the fixed ladder siderails.
 - (d) Rungs or steps on the portable ladder shall be spaced to be identical with rungs or steps on the fixed ladder when the portable ladder is attached for use. The design criteria shall be to achieve a horizontal plane relationship on the top (walking surface) portion of both steps when overlapping is necessary.
 - (e) The portable ladder shall be equipped with a hold-out device near the bottom to assure clearance behind the steps as required by subsection (4)(b)(v) of this section.

Figure D-1

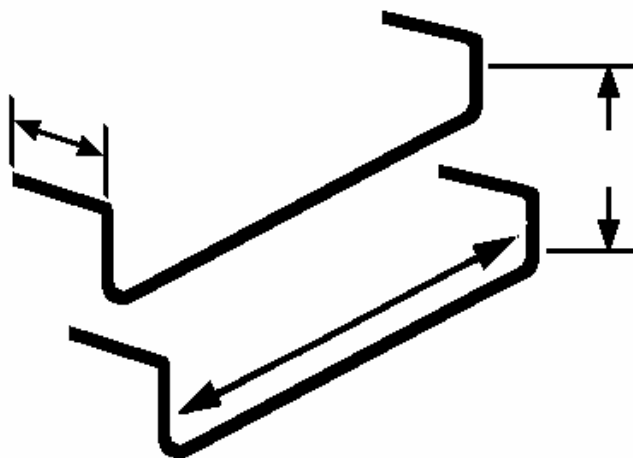

WAC 296-59-115 (Cont.)

Figure D-2

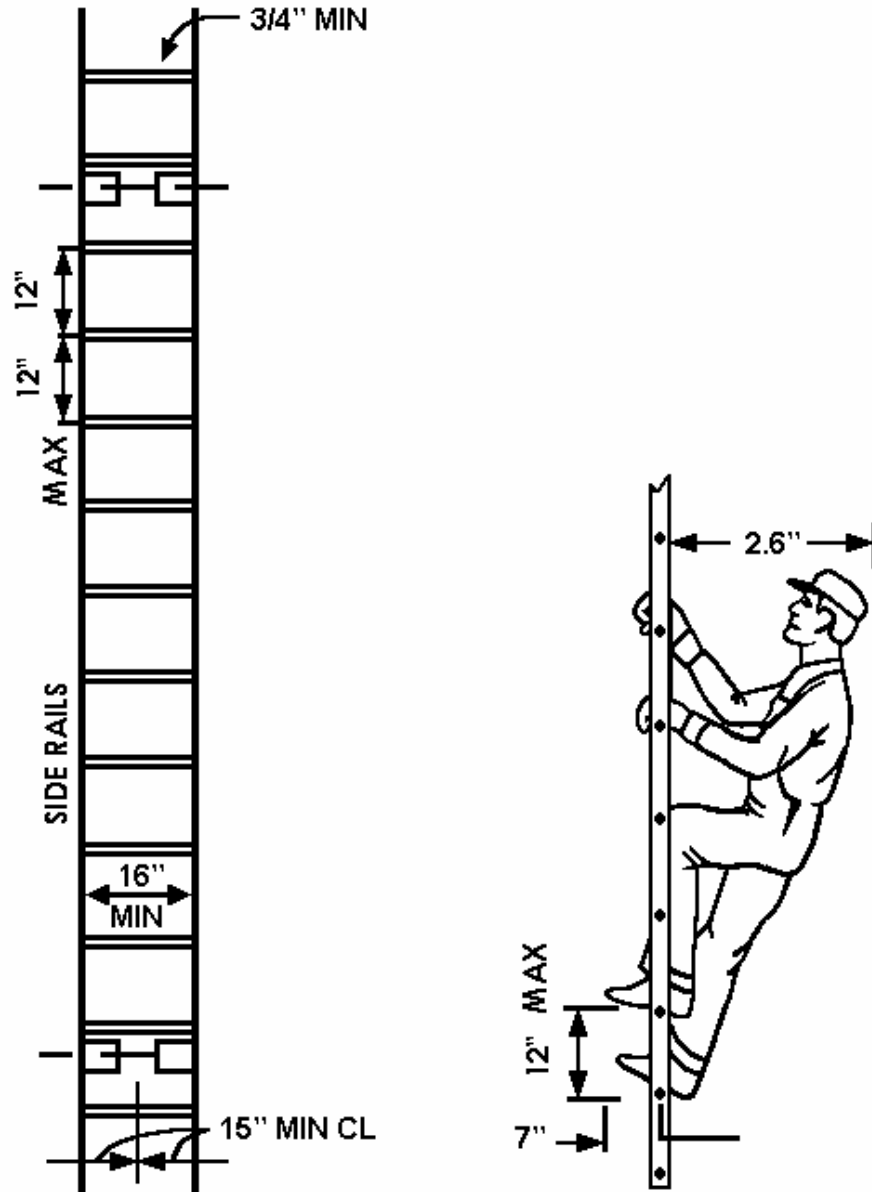

WAC 296-59-115 (Cont.)

Figure D-3

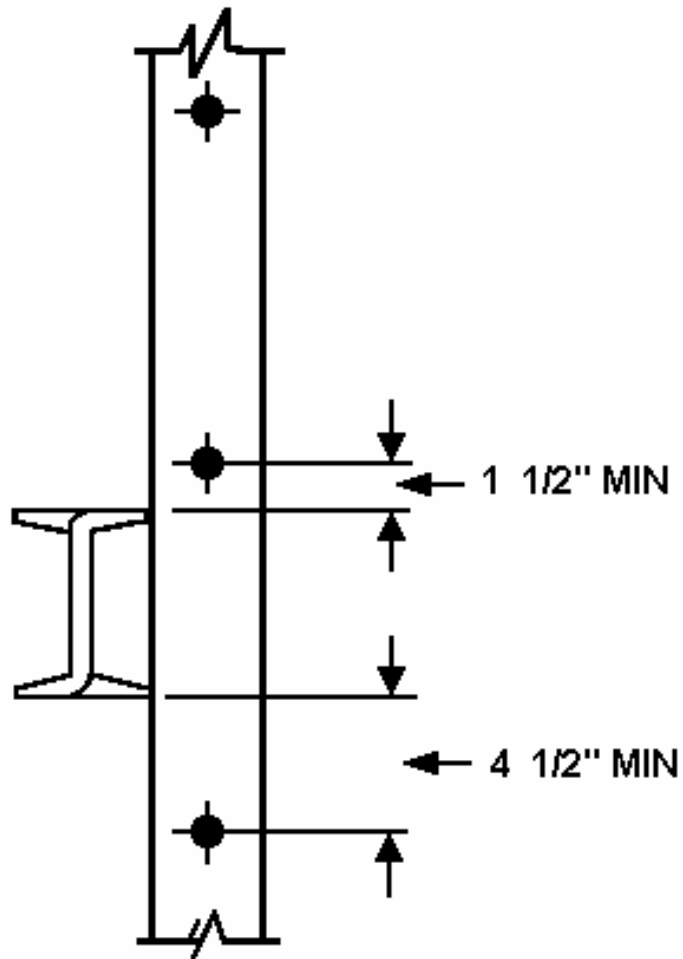

WAC 296-59-115 (Cont.)

Figure D-4

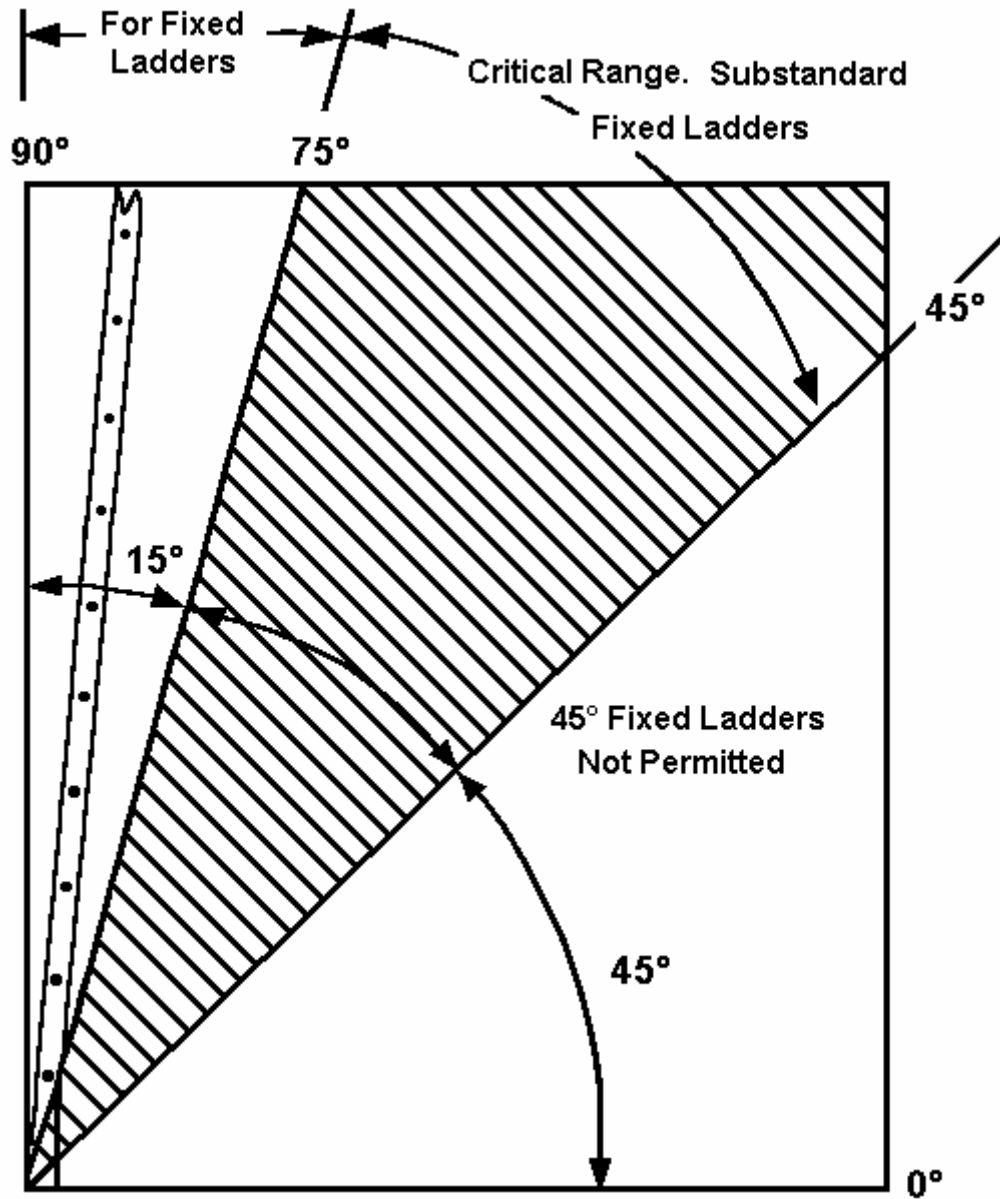

[Statutory Authority: Chapter 49.17 RCW. 88-14-108 (Order 88-11), § 296-59-115, filed 7/6/88.]

WAC 296-59-120 Ski lift operations.

- (1) Operators.
 - (a) Only trained and qualified lift operators shall be permitted to operate any lift while it is carrying passengers.
 - (b) Management designated trainees shall only be permitted to operate a lift while under the direct supervision of a qualified operator or trainer.
 - (c) Initial training of operators shall be accomplished when the lift isn't carrying passengers.
 - (d) Operator training shall include:
 - (i) Standard and emergency start-up procedures;
 - (ii) Standard and emergency stopping procedures;
 - (iii) Lockout procedures;
 - (iv) Corrective actions for operating malfunctions;
 - (v) Specific instructions on who to contact for different kinds of rescue emergencies;
 - (vi) Specific instructions on standard operating procedures with respect to the hazard of loading or unloading passengers proximate to the moving lift chairs.
- (2) Operators and helpers shall prepare and maintain the loading and unloading work stations in a leveled condition and, to the extent possible, free from slipping hazards caused by ice, ruts, excessive snow accumulation, tools, etc.
- (3) Daily start-up procedure.
 - (a) Loading station operators shall test all operating controls and stopping controls before permitting any personnel or passengers to load on the lift.
 - (b) The lift must travel a distance of two times the longest tower span before any employee can load on a chair to go to the remote station.
 - (c) A qualified operator shall be the first passenger on each lift each day.

Exception: The avalanche control team and the emergency rescue team may use any operable lift at anytime for that work. They may use lifts without a remote operator provided that direct communications are maintained to the operator and the operator has successfully completed normal daily safety and operating control checks at the operating station in use.

 - (d) Enroute to the remote station, the remote operator shall visually inspect each tower as the chair or gondola proceeds to the remote station.
 - (e) The remote operator shall stop the system when he/she has reached the remote control station. The operator shall then conduct the daily safety and operating control checks on the remote station.
 - (f) The remote operator shall ensure that the unloading area is groomed to adequately accommodate normal unloading.
 - (g) When all controls are checked and functioning correctly and the unloading area is prepared, the remote operator shall communicate to the operator that the system can be placed in normal operation.
- (4) Operators shall report to their work station wearing adequate clothing for inclement weather which may be encountered. This requirement shall include reasonably water resistant footwear which shall have a slip resistant sole tread.

WAC 296-59-120 (Cont.)

- (5) While the lift is in operation and carrying passengers, operators shall not permit any activity in the loading/unloading areas which could distract their attention from the principle duty of safely loading or unloading passengers.
- (6) Means of communication shall be maintained between the top operator and bottom operator stations.
Statutory Authority: Chapter 49.17 RCW. 88-14-108 (Order 88-11), § 296-59-120, filed 7/6/88.]

WAC 296-59-125 Ski lift aerial work platforms.

- (1) Construction and loading.
- (a) All aerial work platforms shall be constructed to sustain the permissible loading with a safety factor of four. The load permitted shall be calculated to include:
- (i) The weight of the platform and all suspension components;
 - (ii) The weight of each permitted occupant calculated at two hundred fifty pounds per person including limited handtools;
 - (iii) The weight of any additional heavy tools, equipment, or supplies for tasks commonly accomplished from the work platform.
- (b) The floor of the platform shall not have openings larger than two inches in the greatest dimension.
- (c) The platform shall be equipped with toeboards at least four inches high on all sides.
- (d) Guardrails.
- (i) The platform shall be equipped with standard height and strength guardrails where such guardrails will pass through the configuration of all lifts on which it is intended to be used.
 - (ii) Where guardrails must be less than thirty-six inches high in order to clear carriages, guideage, etc., guardrails shall be as high as will clear the obstructions but never less than twelve inches high.
 - (iii) If the work platform is equipped with an upper work level, the upper level platform shall be equipped with a toeboard at least four inches high.
 - (iv) Each platform shall be equipped with a lanyard attachment ring for each permissible occupant to attach a safety belt lanyard.
 - (v) Each lanyard attachment ring shall be of such strength as to sustain five thousand four hundred pounds of static loading for each occupant permitted to be attached to a specific ring.
 - (vi) Attachment rings shall be permanently located as close to the center balance point of the platform as is practical.
 - (vii) The rings may be movable, for instance, up and down a central suspension rod, but shall not be completely removable.
- (e) Platform attachment.
- (i) The platform shall be suspended by either a standard wire rope four part bridle or by solid metal rods, bars, or pipe.
 - (ii) The attachment means chosen shall be of a type which will prevent accidental displacement.
 - (iii) The attachment means shall be adjusted so that the platform rides level when empty.

WAC 296-59-125 (Cont.)

- (f) Maintenance.
 - (i) Every aerial work platform shall be subjected to a complete annual inspection by qualified personnel.
 - (ii) The inspection shall include all structural members, welding, bolted or treaded fittings, and the suspension components.
 - (iii) Any defect noted shall be repaired before the platform is placed back in service.
 - (iv) A written record shall be kept for each annual inspection. The record shall include:
 - (A) The inspector identification;
 - (B) All defects found;
 - (C) The identity of repair personnel;
 - (D) Identity of the post-repair inspector who accepted the platform for use.
 - (g) The platform shall be clearly identified as to the number of permissible passengers and the weight limit of additional cargo permitted.
 - (i) Signs shall be applied on the outside of each side panel.
 - (ii) Signs shall be maintained in clearly legible condition.
 - (h) Unless the side guardrail assembly is at least thirty-six inches high on all sides, signs shall be placed on the inside floor or walls to clearly inform all passengers that they must use a safety belt and lanyard at all times when using the platform.
- (2) Work platform use.
- (a) Platforms shall be attached to the haulrope with an attachment means which develops a four to one strength factor for the combined weight of the platform and all permissible loading.
 - (b) The haulrope attachment means shall be designed to prevent accidental displacement.
 - (c) Trained and competent personnel shall attach and inspect the platform before each use.
 - (d) Passengers shall be provided with and shall use the correct safety harness and lanyard for the intended work.
 - (e) Any time a passenger's position isn't protected by a standard guardrail at least thirty-six inches high, the individual shall be protected by a short lanyard which won't permit free-fall over the platform edge.
 - (f) When personnel are passengers on a work platform and their work position requires the use of a safety harness and lanyard, the lanyard shall be attached to the work platform, not to the haulrope or tower.
 - (g) Work platform passengers shall face in the direction of travel when the lift is moving.
 - (h) Tools, equipment and supplies shall be loaded on the platform in such a fashion that the loaded platform can safely pass all towers and appurtenances.

WAC 296-59-125 (Cont.)

- (i) Heavy tools, equipment or supplies shall be secured in place if they could fall over or roll within the platform and create a hazard for passengers.
- (j) When the work crew is traveling on the work platform, the lift shall be operated at a speed which is safe for that particular system and the conditions present.

Note: See Appendix 2 for operating procedure requirements.

[Statutory Authority: Chapter 49.17 RCW. 88-14-108 (Order 88-11), § 296-59-125, filed 7/6/88.]

WAC 296-59-130 Ski lift machinery guarding.

- (1) Moving machine parts that are located within normal reach shall be fitted with safety guards in compliance with chapter 296-806 WAC, Machine safety.
 - (a) The coupling apparatus for the ski lift emergency drive may be provided with a removable or swing guard.
 - (b) When removable or swing guards are used, the guard and mounting means shall be so designed and constructed as to sustain a two hundred fifty pound weight loading without displacement.
- (2) All guards shall be maintained in good condition and shall be secured in place when the equipment is in operation except for inspection and adjustment purposes.
- (3) The drive machinery and primary control apparatus shall be installed in a facility which can prevent access by unauthorized personnel. The access door shall have a sign which states that entry is restricted to authorized personnel.

[Statutory Authority: RCW 49.17.010, .040, .050, and .060. 04-14-028 (Order 01-12), § 296-59-130, filed 06/29/04, effective 01/01/2005.
Statutory Authority: Chapter 49.17 RCW. 88-14-108 (Order 88-11), § 296-59-130, filed 7/6/88.]

WAC 296-59-135 Appendix 1-Nonmandatory alternative lock-out procedure for ski lifts and tows.

- (1) To ensure the safety of all personnel engaged in lift maintenance activities, we insist that the following procedure be strictly adhered to.
 - (a) Criteria.
 - (i) Equipment shall be deactivated and locked or tagged out before an employee is placed in a position where there is a hazard created by exposure to the components of ski lift or tows, equipment and/or systems.
 - (ii) This procedure relies on positive communication to indicate when lock-out safety is assured. At any time this crew is working at a location remote from the control station, this procedure shall be used by only one work crew whose members are working in close proximity to one another.
 - (iii) The operator and all potentially exposed employees shall have a positive means of communication at all times. If anyone loses the communication means, it shall be restored before exposure can occur or lock-out or tag-out can be broken.
 - (iv) Other radio transmissions breaking in or overriding the communications between control operator and remote work crew, if not controlled, can be a problem. There are considerations that should be followed:
 - (A) The first preferred method is to provide an isolated radio channel for communications between operator and remote work crew.

WAC 296-59-135 (Cont.)

- (B) If an isolated radio frequency isn't possible, the entire area crew should be trained to recognize the radio conversation characteristics of this type of work to be notified when the work is in progress and be required to restrict use of their radios.
 - (v) All personnel working under this procedure shall be thoroughly trained in the specific procedures to be followed and their individual requirements. The ski lift or tow controls shall be under control of a fully qualified operator at all times.
 - (vi) Signs shall be posted in motor rooms on the control panel or the master disconnect stating "men working on lifts."
 - (vii) The control operator shall not leave the close proximity of the control station unless the master disconnect is thrown to the off position and padlocked.
 - (viii) The "standby drive" shall be locked out of service in such a manner that precludes the operation of the lift by jumping ignition, throwing a clutch, or hooking up a coupling, etc., whenever work is being performed on the equipment or system.
- Methods for securing "standby drive" may be, but aren't limited to the following:
- (A) Removal to secure a location or locking up "standby" drive coupling chain, belts, etc.;
 - (B) Denying access to the standby motor by locking motor room door.
- (ix) When the crew is working at either terminal in proximity of bullwheels, shafts, guideage, gears, belts, chains, etc., the master disconnect shall be thrown to the off position and padlocked.
- (b) Work chair.
 - (i) Prior to crew loading on work chair, controls and communications shall be thoroughly checked to confirm that they are in good working condition.
 - (ii) The operator and work crew shall discuss and determine the safe speed for that particular lift. At no time shall the work chair travel around either terminal bullwheel except at a very slow speed.
 - (iii) Employees riding in the work chair shall face the direction of travel when chair is in motion.
 - (iv) Employees in work chair shall pay special attention to ensure that equipment or tools, etc., won't be entangled on towers, ramps, or terminals as work chair passes by.
 - (v) Safety belts are required and there is a designated device on each work chair to hook onto. At no time will it be allowed to hook onto the tower or tower equipment while in the work chair, or hook onto a moving part of the lift if standing on the tower.
- (c) Operator and controls.
 - (i) Manual reset stop switches are required on all lifts. The operator shall check and confirm that the lift can't be started from any control location when the stop switch is depressed. The operator will leave the stop switch depressed until remote crew directs that they are ready to move.
 - (ii) Communications between operator and remote work crew will be on name basis. This is especially important if there are other radio communications or other crews working on other lifts.

WAC 296-59-135 (Cont.)

(2) Summation.

(a) If all these rules are adhered to, the operator can use the control circuit stop switch for repetitive type maintenance on towers. If the remote crew is to be at the location for some time, it is recommended that the operator throw the master disconnect switch to the off position and padlock it.

(b) A padlock on the disconnect switch is required when anybody is working on either terminal.

[Statutory Authority: Chapter 49.17 RCW. 88-23-054 (Order 88-25), § 296-59-135, filed 11/14/88.]