Chapter 296-59 WAC
Safety Standards for Ski Area Facilities and Operations
(Form Number F414-048-000)

This book contains rules for Safety Standard for ski area facilities and operations, as adopted under the Washington Industrial Safety and Health Act of 1973 (Chapter 49.17 RCW).

The rules in this book are effective October 2020. A brief promulgation history, set within brackets at the end of this chapter, gives statutory authority, administrative order of promulgation, and date of adoption of filing.

TO RECEIVE E-MAIL UPDATES:

- Sign up at https://public.govdelivery.com/accounts/WADLI/subscriber/new?topic_id=WADLI_19

TO PRINT YOUR OWN PAPER COPY OR TO VIEW THE RULE ONLINE:

- Go to <https://www.lni.wa.gov/safety-health/safety-rules/rules-by-chapter/?chapter=59/>

DOSH CONTACT INFORMATION:

- **Physical address:**
7273 Linderson Way
Tumwater, WA 98501-5414
(Located off I-5 Exit 101 south of Tumwater.)
- **Mailing address:**
DOSH Standards and Information
PO Box 44810
Olympia, WA 98504-4810
- Telephone: 1-800-423-7233
- For all L&I Contact information, visit <https://www.lni.wa.gov/agency/contact/>
- **Also available on the L&I Safety & Health website:**
 - DOSH Core Rules
 - Other General Workplace Safety & Health Rules
 - Industry and Task-Specific Rules
 - Proposed Rules and Hearings
 - Newly Adopted Rules and New Rule Information
 - DOSH Directives (DD's)
 - See <http://www.lni.wa.gov/Safety-Health/>

Chapter 296-59 WAC

SAFETY STANDARDS FOR SKI AREA FACILITIES AND OPERATIONS

Last Updated: 09/01/2017

WAC	Page
WAC 296-59-001 Foreword.....	1
WAC 296-59-003 Scope and application.....	1
WAC 296-59-005 Incorporation of other standards.....	2
WAC 296-59-007 Definitions.....	2
WAC 296-59-010 Safe place standards.....	4
WAC 296-59-015 General requirements.....	4
WAC 296-59-020 Management's responsibility.....	5
WAC 296-59-025 Employee's responsibility.....	5
WAC 296-59-027 Work activities which include skiing.....	5
WAC 296-59-030 Safety bulletin board.....	5
WAC 296-59-035 First aid.....	5
WAC 296-59-050 Personal protective equipment, general requirements.....	6
WAC 296-59-055 Lockout requirements.....	7
WAC 296-59-060 Vessel or confined area requirements.....	10
WAC 296-59-065 Fire protection and ignition sources.....	10
WAC 296-59-070 Illumination.....	10

WAC 296-59-075 Electrical equipment and distribution.....	11
WAC 296-59-080 Installation, inspection, and maintenance of pipes, piping systems, and hoses.....	11
WAC 296-59-085 Scaffolds, construction, use, and maintenance.	14
WAC 296-59-090 Mobile equipment and lift trucks.	14
WAC 296-59-095 Requirements for cranes and hoists — General safety and health standards to prevail.	17
WAC 296-59-115 Ski lift facilities and structures.	18
WAC 296-59-120 Ski lift operations.	25
WAC 296-59-125 Ski lift aerial work platforms.	27
WAC 296-59-130 Ski lift machinery guarding.	28
WAC 296-59-135 Appendix 1 — Nonmandatory alternative lock-out procedure for ski lifts and tows.	29

WAC 296-59-001 Foreword.

- (1) This vertical standard is promulgated in accordance with applicable provisions of the Washington State Administrative Procedure Act, chapter 34.04 RCW, and the Washington Industrial Safety and Health Act, chapter 49.17 RCW.
- (2) The requirements of this chapter must be applied through the department of labor and industries, division of industrial safety and health, in accordance with administrative procedures provided for in chapter 49.17 RCW, and chapters [296-27](#), [296-360](#), [296-800](#), and [296-900](#) WAC.

WAC 296-59-003 Scope and application.

- (1) The rules of this chapter are applicable to all persons, firms, corporations, or others engaged in the operation of organized ski areas and facilities within the jurisdiction of the department of labor and industries. These rules must augment the WAC general horizontal standards, specifically referenced WAC vertical standards, and specifically referenced national standards or manuals.
- (2) In the event that specific provisions of this chapter may conflict with any other WAC chapter, national standard, or manual, the provisions of this chapter must prevail.
- (3) The rules of this chapter must not be applied to rescue crews during the time that rescue procedures are in process provided that reasonably prudent methods, equipment, and processes are employed. Personnel directly engaged in rescue operations must not be subjected to the immediate restraint provisions of RCW [49.17.130](#).
- (4) Nothing herein contained must prevent the use of existing ski lift and tow equipment during its lifetime unless specific requirements of this chapter require retrofitting or modifications, provided that it must be in conformance with applicable national or state code requirements at the time of manufacture and be maintained in good condition to conform with safety factors for the materials and method of manufacture used.
- (5) Severability. If any provision of this chapter, or its application to any person, firm, corporation, or circumstance is held invalid under state (RCW) or national (Public Law) laws, the remainder of this chapter, or the application of the provision to other persons or circumstances is not affected.
- (6) Variance and procedure. Recognizing that conditions may exist which do not exactly meet the literal requirements of this or other applicable Title [296](#) WAC standards, pursuant to RCW [49.17.080](#) and [49.17.090](#), the director of the department of labor and industries or his/her authorized representative may permit a variance when other means of providing an equivalent measure of protection are afforded. The specific requirements and procedures for variance application are contained in chapter [296-900](#) WAC, Administrative rules. Application forms may be obtained from the assistant director for safety and health or from regional departmental offices.

WAC 296-59-005 Incorporation of other standards.

- (1) Lifts and tows must be designed, installed, operated, and maintained in accordance with American National Standard Institute (ANSI) B77.1-1982, Standards for Passenger Tramways -- Aerial Tramways and Lifts, Surface Lifts, and Tows -- Safety Requirements.
- (2) Future revised editions of ANSI B77.1-1982 may be used for new installations or major modifications of existing installations, as recommended or approved by the equipment manufacturer or a qualified design engineer, except that, where specific provisions exist, variances must be requested from the department.
- (3) Reserved.
- (4) The use of military type weapons for avalanche control must comply with all requirements of the United States government and/or the military branch having jurisdiction. Compliance must include qualification of employees, security requirements, and storage and handling of ammunition.
- (5) You must develop and maintain a chemical hazard communication program as required by WAC [296-901-140](#), which will provide information to all employees relative to hazardous chemicals or substances to which they are exposed, or may become exposed, in the course of their employment.
- (6) When employees perform activities such as construction work or logging, the WAC chapter governing the specific activity must apply, e.g., chapter [296-155](#) or [296-54](#) WAC, et seq.

WAC 296-59-007 Definitions.

Act. The Washington Industrial Safety and Health Act of 1973, RCW 49.17.010 et seq.

Aerial work platform. Any form of work platform, work chair, or workbasket designed to lift or carry workmen to an elevated work position.

ANSI. The American National Standards Institute.

Approved. Approved by the director of the department of labor and industries except where this code requires approval by another specific body or jurisdiction authority.

ASME. The American Society of Mechanical Engineers.

Authorized person. A person approved or assigned by the employer to perform specific duties or to be at specific restricted locations.

Avalanche. The sliding or falling of a large amount of snow down a steep slope which has a destructive force due to its mass.

Belay. To provide an anchor for a safety line when a person is working in a position exposed to falling or sliding, the mountaineering term.

Department. The department of labor and industries, division of industrial safety and health, unless the context clearly indicates otherwise.

Designated. Appointed or authorized by the highest management authority available at the site.

Director. The director of the department of labor and industries or his/her designated representative.

Hazard. That condition, potential or inherent, which might cause injury, death, or occupational disease.

Hazardous material system. Any system within the following classifications:

- (a) **Flammable or explosive.** Any system containing materials which are hazardous because they are easily ignited and create a fire or explosion hazard, defined by NFPA as Class 1 liquids;
- (b) **Chemically active or toxic.** Any system containing material which offers corrosion or toxic hazard in itself or can be productive of harmful gases upon release, defined by NFPA 704M as Class 3 and 4 materials;
- (c) **Thermally hazardous.** Any system above 130° which exposes persons to potential thermal burns;
- (d) **Pressurized.** Any gaseous system above two hundred psig or liquid system above five hundred psig.

Lift certificate to operate. An operating certificate issued by the Washington state parks and recreation commission pursuant to chapter 70.88 RCW subsequent to annual inspections as required by chapter 352-44 WAC.

Must. Indicates a mandatory requirement.

N.E.C. The National Electric Code, as published by either the National Fire Protection Association or ANSI.

Occupied building. A building regularly occupied in whole or in part as a habitation for human beings, or any church, schoolhouse, railroad station, store, or other building where people are accustomed to assemble.

Piping system. Any fixed piping, either rigid pipe or flexible hose, including all fittings and valves, in either permanent or temporary application.

Qualified. One who, by possession of a recognized degree, certificate, license, or professional standing, has successfully demonstrated the personal ability to solve or resolve problems relating to the subject matter, the work, or the project.

RCW. The Revised Code of Washington, legislative law.

ROPS. Rollover protective structure.

S.A.E. The society of automotive engineers.

Safety factor. The ratio of ultimate breaking strength of any member or piece of material or equipment to the actual working stress or safe load when in use.

Should. Indicates a recommended practice.

WAC. The Washington Administrative Code.

WISHA. Washington industrial safety and health administration.

WAC 296-59-010 Safe place standards.

The safe place requirements of the safety and health core rules, WAC [296-800-110](#), must be applicable within the scope of chapter 296-59 WAC.

WAC 296-59-015 General requirements.

- (1) The use of any machinery, tool, material, or equipment which is not in compliance with any applicable requirement of this chapter is prohibited. Such machine, tool, material, or equipment must either be identified as unsafe by tagging or locking the controls to render them inoperable or must be physically removed from its place of operation.
- (2) You must permit only those employees qualified by training or experience to operate equipment and machinery.
- (3) Employees must use safeguards provided for their protection.
- (4) Loose or ragged clothing, scarfs, or ties must not be worn while working around moving machinery.
- (5) Workers should not be assigned or permitted to occupy work locations directly under other workers. When such practice is unavoidable, all parties must be made aware of the potential hazard and adequate protective measures must be taken. When adequate protective measures are not available, one party must be moved to eliminate the potential exposure.
- (6) Employees must report to their employers the existence of any unsafe equipment or method, or any other hazard which, to their knowledge, is unsafe. Where such unsafe equipment or method or other hazard exists in violation of this chapter it must be corrected.
- (7) Housekeeping.
 - (a) All places of employment must be kept clean to the extent that the nature of the work allows.
 - (b) The floor of every workroom must be maintained so far as practicable in a dry condition. Where wet processes are used, drainage must be maintained. Where necessary or appropriate, waterproof footwear must be worn.
 - (c) To facilitate cleaning, every floor, working place, and passageway must be kept free from protruding nails, splinters, loose boards, unnecessary holes and openings or other tripping hazards.
 - (d) Cleaning and sweeping must be done in such a manner as to minimize the contamination of the air with dust and so far as is practical, must be done outside of working hours.
- (8) Requirements for warning signs. Ski area operations which use any form of explosive device for avalanche control must display warning, information placards and/or signs as found in chapter [296-52](#) WAC, Part G.

WAC 296-59-020 Management's responsibility.

The “safe work environment” section of the safety and health core rules, WAC [296-800-110](#), will be applicable within the scope of chapter 296-59 WAC.

WAC 296-59-025 Employee's responsibility.

The “employee responsibilities” section of the safety and health core rules, WAC [296-800-120](#), will be applicable within the scope of chapter 296-59 WAC.

WAC 296-59-027 Work activities which include skiing.

Management must develop a written safety program for all employees whose job duties include skiing. The program must include but is not limited to the following:

- (1) The skiing ability and physical condition of individuals must be considered when determining individual job assignments;
- (2) The ski equipment used must be appropriate for the individual when performing any given job assignment;
- (3) The condition of all ski equipment must be checked by a qualified individual at the beginning of each ski season;
- (4) Employees must be instructed not to use ski equipment until it has been checked and approved;
- (5) Employees must be instructed to ski within their ability and in control at all times;
- (6) Employees must be required to check all ski equipment, including adjustments, before starting work each day;
- (7) Employees must be instructed not to use ski equipment which is defective or out of adjustment.

WAC 296-59-030 Safety bulletin board.

The “safety bulletin board” requirements of the safety and health core rules, WAC [296-800-190](#), will be applicable within the scope of chapter 296-59 WAC.

WAC 296-59-035 First aid.

The first-aid provisions of the safety and health core rules, WAC [296-800-150](#) apply within the scope of chapter 296-59 WAC.

WAC 296-59-050 Personal protective equipment, general requirements.

- (1) Application.
 - (a) Protective equipment, including personal protective equipment for eyes, face, head, and extremities, protective clothing, respiratory devices, and protective shields and barriers, must be provided at no cost to the employee, used, and maintained in a sanitary and reliable condition wherever it is indicated by reason of hazards of processes or environment, chemical hazards, radiological hazards, or mechanical irritants encountered in a manner capable of causing injury or impairment in the function of any part of the body through absorption, inhalation, or physical contact.
 - (b) Employee-owned equipment. Where employees provide their own protective equipment, you must be responsible to ensure its adequacy, including proper maintenance, and sanitation of such equipment.
 - (c) Design, construction, testing, and use of personal protective equipment must comply with the requirements of the safety and health core rules, WAC [296-800-160](#); the Occupational health standards -- Safety standards for carcinogens, chapter [296-62](#) WAC; or the currently applicable ANSI standard.
- (2) Eye and face protection. Eye and face protective equipment must be provided and worn where there is exposure in the work process or environment to hazard of injury, which can be prevented by such equipment.
- (3) Occupational head protection. Employees working in areas where there is a possible danger of head injury from impact, or from falling or flying objects, or from electrical shock and burns, must be protected by protective helmets, i.e., a lift operator would not be required to use a hardhat while operating the lift. However, if that same person is assisting with maintenance operations and is working under a tower where overhead work is being done, that operator would now be required to wear an approved helmet.
 - (a) Helmets for the protection of employees against impact and/or penetration of falling and flying objects must meet the specifications contained in American National Standards Institute, Z89.1-1986, Safety Requirements for Industrial Head Protection.
 - (b) Helmets for the head protection of employees exposed to high voltage electrical shock and burns must meet the specifications contained in American National Standards Institute, Z89.2-1971, Safety Requirements for Industrial Protective Helmets for Electrical Workers, Class B.
 - (c) Approved head protection must be worn by operators of snowmobiles and other mobile oversnow equipment which is not equipped with a rigid metal operator's cab.
- (4) Occupational foot protection.
 - (a) Substantial footwear appropriate for the work conditions encountered must be worn by all employees.
 - (b) Where the job assignment includes exposure to slipping hazards, soles and heels of footwear must be of such material and design as to reduce the hazard of slipping.

- (5) Requirements for safety belts, lifelines, lanyards, and nets must be in accordance with chapter [296-880](#) WAC, Unified safety standards for fall protection.

WAC 296-59-055 Lockout requirements.

- (1) You must develop a formal written policy and procedure for lockout requirements. The policy must embody the principles of subsection (2) of this section and must clearly state that the procedures must be applied in all instances.
- (a) The lockout policy must be posted on all required employee bulletin boards.
 - (b) The lockout policy and procedures must be made a part of new employee orientation and employee training programs.
 - (c) Supervisors and crew leadpersons must ensure compliance with the published policy and procedures in all instances.
- (2) Whenever the unexpected startup of machinery, the energizing of electrical circuits, the flow of material in piping systems, or the removal of guards would endanger workers, such exposure must be prevented by deactivating and locking out the controls as required by this section.
- (3) Equipment requirements.
- (a) You must provide and each employee must use as many padlocks, tags, chains, or devices as are necessary to implement these requirements.
 - (b) Provisions must be made whereby the source of power or exposure can be locked out in accordance with the requirements of this section.
 - (c) On electrically powered equipment, “stop/start” control switches must not be used as lockout switches. Lockout switches must be the primary circuit disconnects and must adequately separate both the power source and any auxiliary power unit from the prime mover so that accidental startup of the equipment being locked out is precluded.
 - (d) Keyed-alike locks, which all open with identical keys, must not be issued as personal lockout locks.
- (4) Training requirements.
- (a) Each person who will be given authority to implement these requirements must first be thoroughly trained in the requirements and procedures.
 - (b) Before being given authority to deactivate and lockout a particular system or piece of equipment, authorized personnel must be made fully aware of all power sources and/or material entry sources which may offer exposure.
 - (c) Checklists must be used to implement effective lockout procedures for complex systems or equipment.
 - (i) Complex is identified as those systems or equipment which require the locking out of four or more controls to ensure isolation or which have controls remote from the immediate work area.

- (ii) Checklists must identify all controls necessary to achieve isolation at the intended worksite(s).
 - (iii) Checklists must provide a space after each listed control to be used for the identity of the person(s) who performed the lockout and required postlockout tests of each control.
 - (iv) Checklists must be prepared by qualified personnel and approved by the responsible area supervisor before each use.
- (5) Control procedure.
 - (a) Each person who could be exposed to the hazard must apply a personal padlock on each control mechanism. Padlocks must be applied in such a manner as to physically block the controls from being moved into the operating position. Each lock must be personally identified or an information tag identifying the owner must be attached to the lock.
 - (b) Padlocks used in lockout procedures may only be removed by the person identified on the lock, except, when it is positively determined that the owner/user of the lock has left the premises without removing a lock, the job supervisor may remove the lock in accordance with a specific procedure formulated by the local plant labor management safety committee or approved by the department.
- (6) Testing after lockout or tagout. After tagging or locking out equipment, a test must be conducted to ascertain that the equipment has been made inoperative or the flow of material has been positively stopped. Precautions must be taken to ascertain that persons will not be subjected to any hazard while conducting the test if the power source or flow of material is not shut off.
- (7) Temporary or alternate power to be avoided. Whenever possible, temporary or alternate sources of power to the equipment being worked on must be avoided. If the use of such power is necessary, all affected employees must be informed and the source of temporary or alternate power must be identified.
- (8) Where tags or signs are required to implement the lockout and control procedures, the tag and attachment device must be constructed of such material that it will not be likely to deteriorate in the environment that it will be subjected to.
- (9) Provisional exception. Electrical lighting and instrument circuits of two hundred forty volts or less on single phase systems or two hundred seventy-seven volts on three-phase systems may be exempted from the lockout requirements of subsection (5)(a) of this section provided that:
 - (a) An information tag meeting the requirements of subsection (8) of this section is used in lieu of a padlock.
 - (b) The information tag must be placed on the switch or switch cover handle in such a manner as to easily identify the deactivated switchgear.
- (10) Deactivating piping systems.
 - (a) Hazardous material systems are defined as:
 - (i) Gaseous systems that are operated at more than two hundred psig;

- (ii) Systems containing any liquid at more than five hundred psig;
 - (iii) Systems containing any material at more than 130°F;
 - (iv) Systems containing material which is chemically hazardous as defined by NFPA 704 M Class 3 and 4;
 - (v) Systems containing material classified as flammable or explosive as defined in NFPA Class I.
- (b) Lockout of piping systems must provide isolation to the worksite, including backflow where such potential exists and where the system is classified as a hazardous material system. The required method must be applied based on the content of the system as specified below:
- (i) Nonhazardous systems must be deactivated by locking out either the pump or a single valve.
 - (ii) Hazardous material systems must be deactivated by one of the following methods:
 - (A) Locking out both the pump and one valve between the pump and the worksite;
 - (B) Locking out two valves between the hazard source and the worksite;
 - (C) Installing and locking out a blank flange between the hazard source and worksite.

Exception:
<p>Aerial tramways and lifts, surface lifts and tows. It is recognized that some inspection, testing, running adjustments, and maintenance tasks cannot be accomplished on this equipment while using standard lockout procedures, particularly when using a work platform suspended from the haulrope. Management of each ski area shall therefore develop a specific written procedure to be used in any instance where any potentially exposed personnel cannot personally lock the controls. The procedure for each area shall meet the following minimum requirements:</p> <ul style="list-style-type: none"> (I) The controls must be attended by a qualified operator at all times when personnel are in potentially exposed work positions and the controls are not padlocked out. (II) Direct communication capability between the control operator and remote work crew must be maintained at all times. (III) All personnel involved must be thoroughly trained in the exact procedures to be followed. (IV) Extension tools which minimize personnel exposure must be used where possible. (V) The equipment must be operated at the slowest speed possible consistent with the task at hand.

- (VI) This exception must not be used by more than one workcrew at more than one remote location on any single piece of equipment or system.
- (VII) This exception is limited to work on the haulrope, towers, and replacing bullwheel liners. For all other work on the bullwheels or drive operations, the master disconnect must be deactivated and locked out.

Note: See Appendix 1 for illustrative example.

WAC 296-59-060 Vessel or confined area requirements.

The requirements of chapter [296-809](#) WAC, Confined spaces, will be applicable within the scope of chapter 296-59 WAC.

WAC 296-59-065 Fire protection and ignition sources.

The requirements of WAC [296-24-585](#) and [296-800-300](#), et seq., relating to fire protection requirements, will be applicable within the scope of chapter 296-59 WAC.

WAC 296-59-070 Illumination.

- (1) Sufficient illumination required. All areas must be sufficiently illuminated in order that persons in the area can safely perform their assigned duties. The recommended levels of illumination specified in the safety and health core rules, WAC [296-800-210](#), must be followed. When areas are not specifically referred to in chapter [296-800](#) WAC and the adequacy of illumination for the area or task performed is questionable, a determination of the amount of illumination needed may be made by the division of industrial safety and health.
- (2) Emergency or secondary lighting system required.
 - (a) There must be an emergency or secondary lighting system which can be actuated immediately upon failure of the normal power supply system. The emergency or secondary lighting system must provide illumination in the following areas:
 - (i) Wherever it is necessary for workers to remain at their machine or station to shut down equipment in case of power failure;
 - (ii) At stairways and passageways or aiseways used by workers as an emergency exit in case of power failure;
 - (iii) In all plant first-aid and/or medical facilities;
 - (iv) In emergency power and control room, i.e., in emergency generator rooms unless arranged to start automatically in the event of power failure, or on ski lift motor drive rooms where it would be necessary for employees to switch on the emergency drive system during night skiing.

- (b) Emergency lighting facilities must be checked at least every thirty days for mechanical defects. Defective equipment must be given priority for repair schedule.
- (3) Extension cord type lights. All extension cord type lights must be provided with proper guards.

WAC 296-59-075 Electrical equipment and distribution.

- (1) National Electrical Code to prevail. All electrical installations and electrical utilization equipment must comply with the National Electrical Code requirements.

Exception:
In instances where (N.E.C.) conflicts with ANSI B77.1 with respect to tramways, surface lifts, or tows, ANSI B77.1 shall prevail.

- (2) Authorized personnel to do electrical work. Only those persons who are qualified to do the work assigned and are authorized by you must be allowed to perform electrical work on any electrical equipment or wiring installations.
- (3) High voltage areas to be guarded. Motor rooms, switch panel rooms, or other areas where persons may come in contact with high voltages must be fenced off or be enclosed in a separate area. The gate, door, or access to such area must be posted with a notice stating that only authorized persons are allowed in the area.
- (4) Control panels. In areas where mobile equipment operates, floor stand panels must be protected from being struck by moving equipment. Start or run handles and buttons must be protected from accidental actuation.
- (5) Switches or control devices. Switches, circuit breakers, or other control devices must be located so that they are readily accessible for activation or deactivation and must be marked to indicate their function or machine which they control. The positions of ON and OFF must be marked or indicated and provision must be made for locking out the circuit.
- (6) Starting requirements for electrically driven equipment after power failure. Electrically driven equipment must be designed so that it will not automatically start upon restoration of power after a power failure if it will create a hazard to personnel.
- (7) Posting equipment automatically activated or remotely controlled. Equipment which is automatically activated or remotely controlled must be posted, warning persons that machine may start automatically if it will create a hazard to personnel.

WAC 296-59-080 Installation, inspection, and maintenance of pipes, piping systems, and hoses.

- (1) Design and installation. All new piping systems intended to be used in hazardous material service must be designed and installed in accordance with applicable provisions of the ASME Code for Pressure Piping or in accordance with applicable provisions of ANSI B31.1 through B31.8. The referenced edition in effect at the time of installation must be utilized.

Note: Both referenced standard have identical requirements.

- (2) Inspection and maintenance.
 - (a) Management must develop a formal program of inspections for all hazardous material piping systems. The program must be based on sound maintenance engineering principles and must demonstrate due consideration for the manufacturing specifications of the pipe, hose, valves, and fittings, the ambient environment of the installation and the corrosive or abrasive effect of the material handled within the system.
 - (b) Type and frequency of tests and/or inspections and selection of inspection sites must be adequate to give indications that minimum safe design operating tolerances are maintained. The tests may include visual and nondestructive methods.
 - (c) You must submit your formal program of initial and ongoing inspections to the department for approval within one year after the effective date of this requirement.
 - (d) All existing hazardous material systems must be inspected to the criteria of this section prior to two years after effective date, or in accordance with a schedule approved by the department.
- (3) Inspection records.
 - (a) Results of inspections and/or tests must be maintained as a record for each system.
 - (b) Past records may be discarded provided the current inspection report and the immediate preceding two reports are maintained.
 - (c) When a system is replaced, a new record must be established and all past records may be discarded.
 - (d) The records for each system must be made available for review by the department upon request.
 - (e) You may omit the inspection requirements for portions of existing systems that are buried or enclosed in permanent structures in such a manner as to prevent exposure to employees even in the event of a failure.
- (4) Systems or sections of systems found to be below the minimum design criteria requirements for the current service must be repaired or replaced with component parts and methods which equal the requirements for new installations.
- (5) Identification of piping systems.
 - (a) Pipes containing hazardous materials must be identified. It is recommended that USAS A13.1 "Scheme for Identification of Piping Systems" be followed.

- (b) Positive identification of piping system content must be identified by lettered legend giving the name of the content in full or abbreviated form, or a commonly used identification system. Such identification must be made and maintained at suitable intervals and at valves, fittings, and on both sides of walls or floors. Arrows may be used to indicate the direction of flow. Where it is desirable or necessary to give supplementary information such as hazard of use of the piping system content, this may be done by additional legend or by color applied to the entire piping system or as colored bands. Legends may be placed on colored bands.

Examples of legends which may give both positive identification and supplementary information regarding hazards or use are:

Ammonia Chlorine Liquid caustic Sulphuric acid Natural gas	Hazardous liquid or gas Hazardous liquid or gas Hazardous liquid Hazardous liquid Flammable/explosive gas
------------------------------------------------------------------------	-----------------------------------------------------------------------------------------------------------------------

Note: Manual L-1, published by Chemical Manufacturers Association, Inc., is a valuable guide in respect to supplementary legend.

- (c) When color, applied to the entire piping system or as colored bands, is used to give supplementary information it should conform to the following:

Classification	Predominant Color
F-Fire protection equipment	Red
D-Dangerous materials	Yellow (or Orange)
S-Safe materials and when required P-Protective material	Green (or the achromatic colors, white, black, gray, or aluminum Bright blue

- (d) Legend boards showing the color and identification scheme in use must be prominently displayed at each plant. They must be located so that employees who may be exposed to hazardous material piping systems will have a frequent reminder of the identification program.
- (e) All employees who work in the area of hazardous material piping systems must be given training in the color and identification scheme in use.

WAC 296-59-085 Scaffolds, construction, use, and maintenance.

- (1) Whenever work must be performed at a height which cannot be reached from the floor or permanent platform and where it would not be a safe practice to use a ladder, a properly constructed scaffold must be provided and used.
- (2) Scaffolds must be constructed and used in compliance with WAC [296-24-860](#) through [296-24-862](#).

WAC 296-59-090 Mobile equipment and lift trucks.

- (1) Mobile equipment must be designed, constructed, maintained, and used in accordance with this section and appropriate ANSI and/or SAE requirements.
- (2) Operator training.
 - (a) Methods must be devised by management to train personnel in the safe operation of mobile equipment.
 - (b) Training programs for all mobile equipment must include the manufacturer's operating instructions when such instructions are available.
 - (c) Only trained and authorized operators must be permitted to operate such vehicles.
- (3) Special duties of operator. Special duties of the operator of a power-driven vehicle must include the following:
 - (a) Test brakes, steering gear, lights, horns, warning devices, clutches, etc., before operating vehicle;
 - (b) Not move a vehicle while an unauthorized rider is on the vehicle;
 - (c) Slow down and sound horn upon approaching blind corners or other places where vision or clearance is limited;
 - (d) Comply with all speed and traffic regulations and other applicable rules;
 - (e) Have the vehicle being operated under control at all times so that he can safely stop the vehicle in case of emergency; and
 - (f) Keep the load on the uphill side when driving a forklift vehicle on a grade.
- (4) Operator to be in proper position. Control levers of lift trucks, front end loaders, or similar types of equipment must not be operated except when the operator is in their proper operating position.
- (5) Raised equipment to be blocked. Employees must not work below the raised bed of a dump truck, raised buckets of front end loaders, raised blades of tractors or in similar positions without blocking the equipment in a manner that will prevent it from falling. When working under equipment suspended by use of jacks, safety stands or blocking must be used in conjunction with the jack.

- (6) Precautions to be taken while inflating tire. Unmounted split rim wheels must be placed in a safety cage or other device must be used which will prevent a split rim from striking the worker if it should dislodge while the tire is being inflated.
- (7) Reporting suspected defects. If, in the opinion of the operator, a power-driven vehicle is unsafe, the operator must report the suspected defect immediately to the person in charge. Any defect which would make the vehicle unsafe to operate under existing conditions must be cause for immediate removal from service. The vehicle must not be put back into use until it has been made safe.
- (8) Safe speed. Vehicles must not be driven faster than a safe speed compatible with existing conditions.
- (9) Unobstructed view.
 - (a) Vehicle operators must have a reasonably unobstructed view of the direction of travel. Where this is not possible, the operator must be directed by a person or by a safe guidance means or device.
 - (b) Where practical, mirrors must be installed at blind corners or intersections which will allow operators to observe oncoming traffic.
 - (c) It is recommended that vehicles operating in congested areas be provided with an automatic audible or visual alarm system.
- (10) Passengers to ride properly.
 - (a) Passengers must not be permitted to ride with legs or arms extending outside the running lines of the cab, FOPS, or ROPS of any vehicle.
 - (b) Passengers on mobile oversnow equipment must ride within the cab unless exterior seating is provided. The exterior seating may include the cargo bed provided that the bed is equipped with sideboards and a tailgate at least ten inches high. If passengers are permitted to stand in the bed, adequate handholds must be provided.
 - (c) The number of passengers and seating arrangements within the cab on any mobile equipment must not interfere with the operator's ability to safely operate the equipment.
 - (d) Exterior passengers must not be permitted on mobile oversnow equipment which has snow grooming equipment mounted on the bed or when the machine is towing any kind of equipment, sleds, etc.
 - (e) Operators must use good judgment with respect to speed and terrain when carrying exterior passengers.
- (11) Horns and lights.
 - (a) Every vehicle must be provided with an operable horn distinguishable above the surrounding noise level.
 - (b) Any vehicle required to travel away from an illuminated area must be equipped with a light or lights which adequately illuminate the direction of travel.

- (12) Brakes on power-driven vehicles. Vehicles must be equipped with brakes and devices which will hold a parked vehicle with load on any grade on which it may be used. The brakes and parking devices must be kept in proper operating condition at all times.
- (13) Cleaning vehicles. All vehicles must be kept free of excessive accumulations of dust and grease which may present a hazard.
- (14) Lifting capacity of vehicle to be observed. At no time must a load in excess of the manufacturer's maximum lifting capacity rating be lifted or carried. Such lifting capacity may only be altered with the approval of the equipment manufacturer or a qualified design engineer.
- (15) Posting rated capacity. The maximum rated lifting capacity of all lift trucks must be posted at all times on the vehicle in such a manner that it is readily visible to the operator.
- (16) Carrying loose material. Lift trucks must not be used to carry loose loads of pipe, steel, iron, lumber, palletized material, rolls of paper, or barrels unless adequate clearance is provided and the loads are stabilized.
- (17) Position of lift forks or clamps. The forks or clamps of lift trucks must be kept as low as possible while the vehicle is moving. They must be lowered to the ground or floor when the vehicle is parked.
- (18) Walking under loads prohibited. No person must be allowed under the raised load of a lift truck, backhoe, or front end loader.
- (19) Hoisting of personnel on vehicle forks prohibited. Personnel must not be hoisted by standing directly on the forks of vehicles.
- (20) Using forklifts as elevated work platforms. A platform or structure built specifically for hoisting persons may be used providing the following requirements are met:
 - (a) The structure must be securely attached to the forks and must have standard guardrails and toeboards installed on all sides;
 - (b) The hydraulic system must be so designed that the lift mechanism will not drop faster than one hundred thirty-five feet per minute in the event of a failure in any part of the system. Forklifts used for elevating work platforms must be identified that they are so designed;
 - (c) A safety strap must be installed or the control lever must be locked to prevent the boom from tilting;
 - (d) An operator must attend the lift equipment while workers are on the platform;
 - (e) The operator must be in the normal operating position while raising or lowering the platform. A qualified operator must remain in attendance whenever an employee is on the work platform;
 - (f) The vehicle must not travel from point to point while workers are on the platform except that inching or maneuvering at very slow speed is permissible; and
 - (g) The area between workers on the platform and the mast must be adequately guarded to prevent contact with chains or other shear points.

- (21) Overhead guards on lift trucks. All lift trucks must be equipped with an overhead guard constructed and installed to conform to USAS B56.1-1969 "Safety Code for Powered Industrial Trucks." This guard may be removed only when it cannot be used due to the nature of the work being performed in which caseloads must be maintained so as not to create a hazard to the operator.
- (22) Protection from exhaust system. Any exhaust system which might be exposed to contact must be properly insulated or isolated to protect personnel. Exhaust systems on lift trucks and jitneys must be constructed to discharge either within twenty inches from the floor or eighty-four inches or more above the floor. The exhausted gases must be directed away from the operator. The equipment must be designed in such a manner that the operator will not be exposed to the fumes.
- (23) Emergency exit from mobile equipment. Mobile equipment with an enclosed cab must be provided with an escape hatch or other method of exit in case the regular exit cannot be used.
- (24) Vehicle wheels chocked. When driving mobile equipment onto the bed of a vehicle, the wheels of the vehicle must be chocked.
- (25) Prevent trailer from tipping. Suitable methods must be used or devices installed which will prevent the trailer from tipping while being loaded or unloaded.
- (26) Refueling. Gasoline or LPG engines must be shut off during refueling.
- (27) Close valve on LPG container. Whenever vehicles using LP gas as a fuel are parked overnight or stored for extended periods of time indoors, with the fuel container in place, the service valve of the fuel container must be closed.
- (28) LPG tanks. LPG vehicle fuel tanks must be installed and protected in a manner which will minimize the possibility of damage to the tank.
- (29) Inspecting and testing of LPG containers. LPG containers must be inspected and tested as required by chapter [296-24](#) WAC.
- (30) Spinners on steering wheels. The use of spinners on steering wheels must be prohibited unless an antikick device is installed or the equipment has a hydraulic steering system.
- (31) The requirements of chapter [296-817](#) WAC, Hearing loss prevention (noise), apply to mobile equipment operation.

WAC 296-59-095 Requirements for cranes and hoists — General safety and health standards to prevail.

All applicable rules for design, construction, maintenance, operation, and testing of cranes and hoists contained in the General safety and health standards, chapter [296-24](#) WAC, must be met.

WAC 296-59-115 *Ski lift facilities and structures.*

- (1) Existing ski lift facilities and structures must not be required to be retrofitted with standard construction work platforms, walkways, stairs or guardrails on exterior surfaces when such features would add significantly to snow loading considerations. When such standard protective features are omitted, alternative personal protective measures must be used where possible. Examples include but are not limited to: Safety belt and lanyard, ladder climbing safety devices, temporary work platforms or scaffolds, temporary or removable handrails, guardrails, or walkways.
- (2) Snow removal.
 - (a) During the operating season, standard guardrails which would interfere with snow removal may be omitted in areas where it can be anticipated that frequent snow removal will be necessary to maintain operability of ski lift apparatus. Examples could include but are not limited to the motor house roof or loading and unloading areas.
 - (b) Personnel barricades, signs, or other devices must be used to deflect traffic or warn personnel of existing fall hazards.
- (3) All ski lift towers installed after the effective date of this standard must be equipped with permanent ladders or steps which meet the following minimum requirements:
 - (a) The minimum design live load must be a single concentrated load of two hundred pounds.
 - (b) The number and position of additional concentrated live load units of two hundred pounds each as determined from anticipated usage of the ladder must be considered in the design.
 - (c) The live loads imposed by persons occupying the ladder must be considered to be concentrated at such points as will cause the maximum stress in the structural member being considered.
 - (d) The weight of the ladder and attached appurtenances together with the live load must be considered in the design of rails and fastenings.
 - (e) All rungs must have a minimum diameter of three-fourths inch.
 - (f) The distance between rungs on steps must not exceed twelve inches and must be uniform throughout the ladder length. The top rung must be located at the level of the landing or equipment served by the ladder.
 - (g) The minimum clear length of rungs or steps must be sixteen inches on new installations.
 - (h) Rungs, cleats, and steps must be free of sharp edges, burrs, or projections which may be a hazard.
 - (i) The rungs of an individual-rung ladder must be so designed that the foot cannot slide off the end. (A suggested design is shown in Figure D-1, at the end of this section.)
 - (j) Side rails which might be used as a climbing aid must be of such cross sections as to afford adequate gripping surface without sharp edges or burrs.

- (k) Fastenings. Fastenings must be an integral part of fixed ladder design.
 - (l) All splices made by whatever means must meet design requirements as noted in (a) of this subsection. All splices and connections must have smooth transition with original members and with no sharp or extensive projections.
 - (m) Adequate means must be employed to protect dissimilar metals from electrolytic action when such metals are joined.
 - (n) Welding. All welding must be in accordance with the “Code for Welding in Building Construction” (AWS D1.0-1966).
 - (o) Protection from deterioration. Metal ladders and appurtenances must be painted or otherwise treated to resist corrosion and rusting when location demands.
- (4) Installation and clearance.
- (a) Pitch.
 - (i) The preferred pitch of fixed ladders is between the range of seventy-five degrees and ninety degrees with the horizontal (Figure D-4).
 - (ii) Substandard pitch. Fixed ladders must be considered as substandard if they are installed within the substandard pitch range of forty-five and seventy-five degrees with the horizontal. Substandard fixed ladders are permitted only where it is found necessary to meet conditions of installation. This substandard pitch range is considered as a critical range to be avoided, if possible.
 - (iii) Pitch greater than ninety degrees. Ladders having a pitch in excess of ninety degrees with the horizontal are prohibited.
 - (b) Clearances.
 - (i) The perpendicular distance from the centerline of the rungs to the nearest permanent object on the climbing side of the ladder must be thirty-six inches for a pitch of seventy-six degrees, and thirty inches for a pitch of ninety degrees (Figure D-2), with minimum clearances for intermediate pitches varying between these two limits in proportion to the slope.
 - (ii) A clear width of at least fifteen inches must be provided each way from the centerline of the ladder in the climbing space.
 - (iii) The side rails of through or side-step ladder extensions must extend three and one-half feet above parapets and landings.
 - (A) For through ladder extensions, the rungs must be omitted from the extension and must have not less than eighteen nor more than twenty-four inches clearance between rails.
 - (B) For side-step or offset fixed ladder sections, at landings, the side rails and rungs must be carried to the next regular rung beyond or above the three and one-half feet minimum.
 - (iv) Grab bars must be spaced by a continuation of the rung spacing when they are located in the horizontal position. Vertical grab bars must have the same spacing as the ladder side rails. Grab bar diameters must be the equivalent of the round-rung diameters.

- (v) Clearance in back of ladder. The distance from the centerline of rungs, cleats, or steps to the nearest permanent object in back of the ladder must be not less than seven inches, except that when unavoidable obstructions are encountered, minimum clearances as shown in Figure D-3 must be provided.
 - (vi) Clearance in back of grab bar. The distance from the centerline of the grab bar to the nearest permanent object in back of the grab bars must be not less than four inches. Grab bars must not protrude on the climbing side beyond the rungs of the ladder which they serve.
- (c) The step-across distance from the nearest edge of a ladder to the nearest edge of the equipment or structure must be not more than twelve inches, or less than two and one-half inches. However, the step-across distance may be as much as twenty inches provided:
- (i) The climber is wearing a safety belt and lanyard; and
 - (ii) The lanyard is attached to the tower structure before the climber steps off the ladder.
- (5) Ski lift towers are not required to be equipped with ladder cages, platforms or landings.
- (6) Maintenance and use.
- (a) All ladders must be maintained in a safe condition. All ladders must be inspected regularly, with the intervals between inspections being determined by use and exposure.
 - (b) When ascending or descending, the climber must face the ladder.
 - (c) Personnel must not ascend or descend ladders while carrying tools or materials which could interfere with the free use of both hands.
- (7) Personnel must be provided with and must use ladder safety devices or safety belts and lanyards whenever feasible.
- (8) Personnel must not place mobile equipment or personal equipment such as skis, ski poles, or large tools within the falling radius of the lift tower while climbing or working on the lift tower.
- (9) Ski lift towers and terminals are not required to be equipped with sheave guards on the haulrope wheels.
- (10) Ski lift towers are not required to be equipped with work platforms.
- (11) Personnel must use personal protective equipment such as a safety belt and lanyard in accordance with the requirements of chapter [296-880](#) WAC, Unified safety standards for fall protection.
- (12) When fixed ladders on towers do not reach all the way down to the ground or snow level, a specifically designed and constructed portable ladder must be used for access to and from the fixed ladder. Portable ladders must be constructed and maintained to the following requirements:
- (a) The portable ladder must be constructed in accordance with applicable provisions of subsection (3) of this section.

- (b) The portable ladder must be constructed with a minimum of two attachment hooks near the top to be utilized for securing the portable ladder onto the fixed ladder.
- (c) The attachment hooks must be installed to support the portable ladder near the fixed ladder side rails.
- (d) Rungs or steps on the portable ladder must be spaced to be identical with rungs or steps on the fixed ladder when the portable ladder is attached for use. The design criteria must achieve a horizontal plane relationship on the top (walking surface) portion of both steps when overlapping is necessary.
- (e) The portable ladder must be equipped with a hold-out device near the bottom to ensure clearance behind the steps as required by subsection (4)(b)(v) of this section.

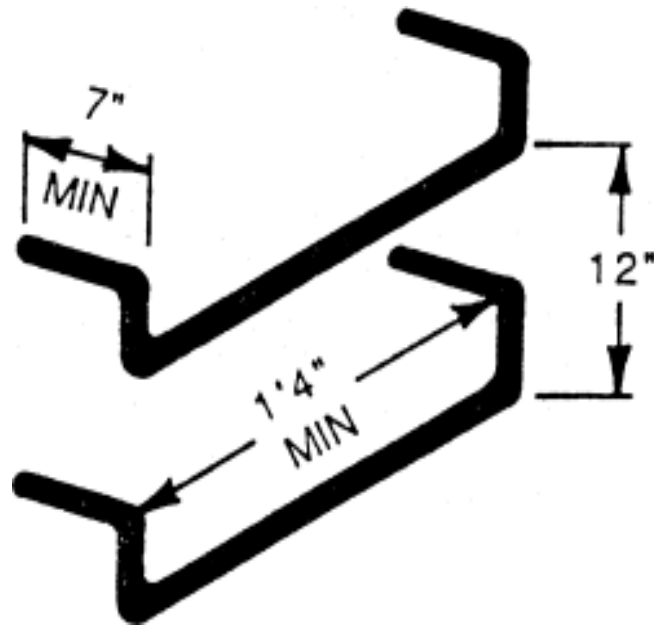

FIGURE D-1

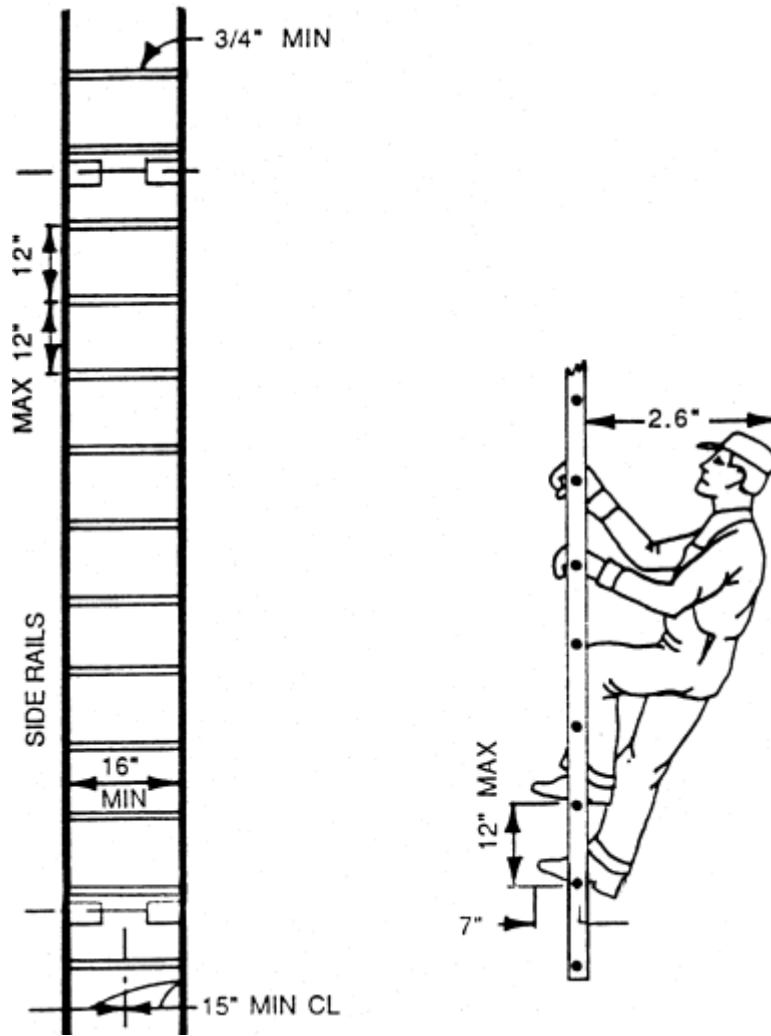

FIGURE D-2
Minimum Ladder Clearance

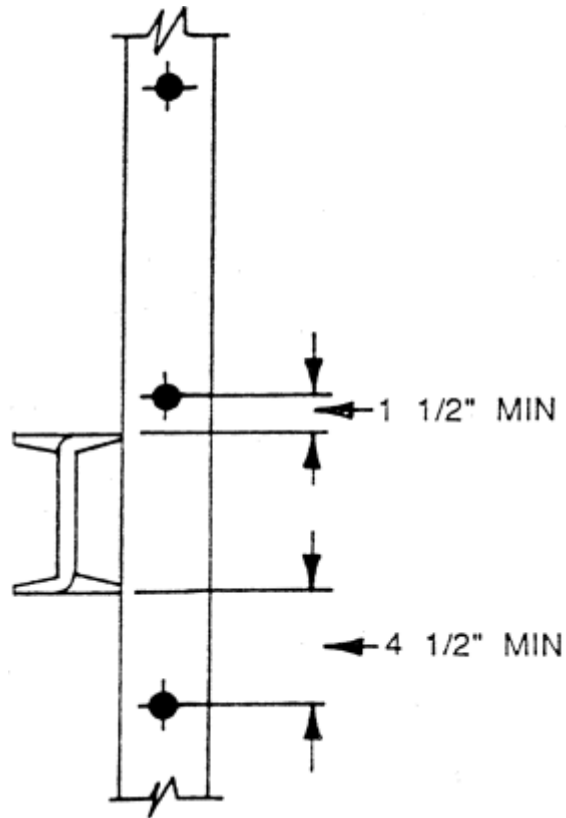

FIGURE D-3
Clearance for Unavoidable Obstruction
at Rear of Fixed Ladder.

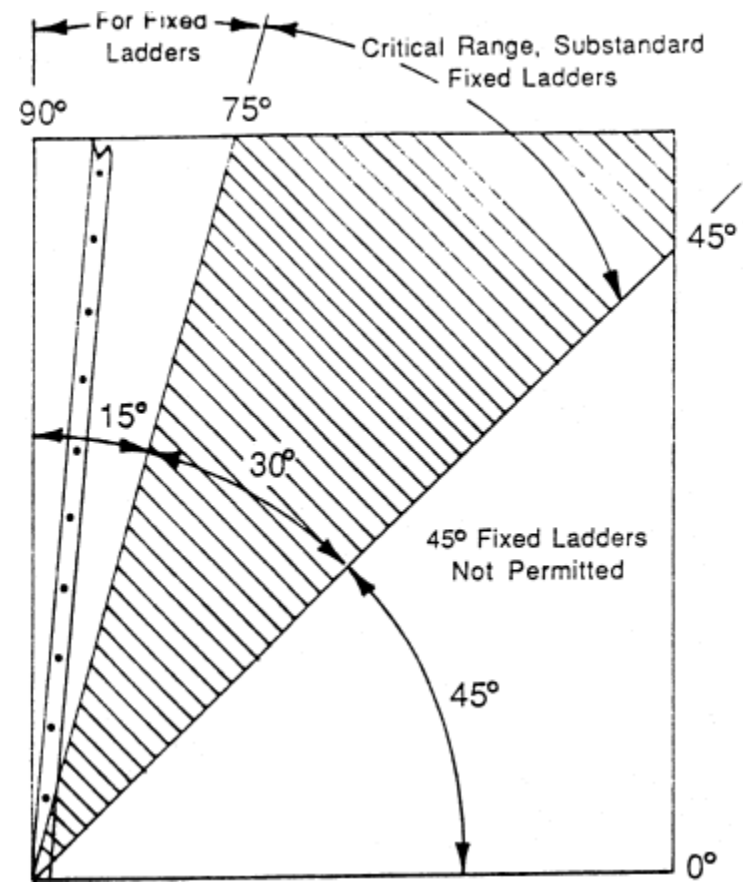

FIGURE D-4
Fixed Ladder Range

WAC 296-59-120 Ski lift operations.

- (1) Operators.
 - (a) Only trained and qualified lift operators must be permitted to operate any lift while it is carrying passengers.
 - (b) Management designated trainees must only be permitted to operate a lift while under the direct supervision of a qualified operator or trainer.
 - (c) Initial training of operators must be accomplished when the lift is not carrying passengers.
 - (d) Operator training must include:
 - (i) Standard and emergency start up procedures;
 - (ii) Standard and emergency stopping procedures;
 - (iii) Lockout procedures;

- (iv) Corrective actions for operating malfunctions;
 - (v) Specific instructions on who to contact for different kinds of rescue emergencies;
 - (vi) Specific instructions on standard operating procedures with respect to the hazard of loading or unloading passengers proximate to the moving lift chairs.
- (2) Operators and helpers must prepare and maintain the loading and unloading work stations in a leveled condition and, to the extent possible, free from slipping hazards caused by ice, ruts, excessive snow accumulation, tools, etc.
- (3) Daily start up procedure.
- (a) Loading station operators must test all operating controls and stopping controls before permitting any personnel or passengers to load on the lift.
 - (b) The lift must travel a distance of two times the longest tower span before any employee can load on a chair to go to the remote station.
 - (c) A qualified operator must be the first passenger on each lift each day.

Exception:
The avalanche control team and the emergency rescue team may use any operable lift at any time for that work. They may use lifts without a remote operator provided that direct communications are maintained to the operator and the operator has successfully completed normal daily safety and operating control checks at the operating station in use.

- (d) Enroute to the remote station, the remote operator must visually inspect each tower as the chair or gondola proceeds to the remote station.
 - (e) The remote operator must stop the system when he/she has reached the remote control station. The operator must then conduct the daily safety and operating control checks on the remote station.
 - (f) The remote operator must ensure that the unloading area is groomed to adequately accommodate normal unloading.
 - (g) When all controls are checked and functioning correctly and the unloading area is prepared, the remote operator must communicate to the operator that the system can be placed in normal operation.
- (4) Operators must report to their work station wearing adequate clothing for inclement weather which may be encountered. This requirement must include reasonably water resistant footwear which must have a slip resistant sole tread.
- (5) While the lift is in operation and carrying passengers, operators must not permit any activity in the loading/unloading areas which could distract their attention from the principle duty of safely loading or unloading passengers.
- (6) Means of communication must be maintained between the top operator and bottom operator stations.

WAC 296-59-125 Ski lift aerial work platforms.

- (1) Construction and loading.
 - (a) All aerial work platforms must be constructed to sustain the permissible loading with a safety factor of four. The load permitted must be calculated to include:
 - (i) The weight of the platform and all suspension components;
 - (ii) The weight of each permitted occupant calculated at two hundred fifty pounds per person including limited handtools;
 - (iii) The weight of any additional heavy tools, equipment, or supplies for tasks commonly accomplished from the work platform.
 - (b) The floor of the platform must not have openings larger than two inches in the greatest dimension.
 - (c) The platform must be equipped with toeboards at least four inches high on all sides.
 - (d) Guardrails requirements must be in accordance with chapter [296-880](#) WAC, Unified safety standards for fall protection.
 - (e) Platform attachment.
 - (i) The platform must be suspended by either a standard wire rope four part bridle or by solid metal rods, bars, or pipe.
 - (ii) The attachment means chosen must be of a type which will prevent accidental displacement.
 - (iii) The attachment means must be adjusted so that the platform rides level when empty.
 - (f) Maintenance.
 - (i) Every aerial work platform must be subjected to a complete annual inspection by qualified personnel.
 - (ii) The inspection must include all structural members, welding, bolted or treaded fittings, and the suspension components.
 - (iii) Any defect noted must be repaired before the platform is placed back in service.
 - (iv) A written record must be kept for each annual inspection. The record must include:
 - (A) The inspector identification;
 - (B) All defects found;
 - (C) The identity of repair personnel;
 - (D) Identity of the postrepair inspector who accepted the platform for use.
 - (g) The platform must be clearly identified as to the number of permissible passengers and the weight limit of additional cargo permitted.
 - (i) Signs must be applied on the outside of each side panel.

- (ii) Signs must be maintained in clearly legible condition.
 - (h) Unless the side guardrail assembly is at least thirty-six inches high on all sides, signs must be placed on the inside floor or walls to clearly inform all passengers that they must use a safety belt and lanyard at all times when using the platform.
- (2) Work platform use.
- (a) Platforms must be attached to the haulrope with an attachment means which develops a four to one strength factor for the combined weight of the platform and all permissible loading.
 - (b) The haulrope attachment means must be designed to prevent accidental displacement.
 - (c) Trained and competent personnel must attach and inspect the platform before each use.
 - (d) Work platform passengers must face in the direction of travel when the lift is moving.
 - (e) Tools, equipment and supplies must be loaded on the platform in such a fashion that the loaded platform can safely pass all towers and appurtenances.
 - (f) Heavy tools, equipment or supplies must be secured in place if they could fall over or roll within the platform and create a hazard for passengers.
 - (g) When the work crew is traveling on the work platform, the lift must be operated at a speed which is safe for that particular system and the conditions present.

Note: See Appendix 1 for operating procedure requirements.

WAC 296-59-130 *Ski lift machinery guarding.*

- (1) Moving machine parts that are located within normal reach must be fitted with safety guards in compliance with chapter [296-806](#) WAC, Machine safety.
 - (a) The coupling apparatus for the ski lift emergency drive may be provided with a removable or swing guard.
 - (b) When removable or swing guards are used, the guard and mounting means must be so designed and constructed as to sustain a two hundred fifty pound weight loading without displacement.
- (2) All guards must be maintained in good condition and must be secured in place when the equipment is in operation except for inspection and adjustment purposes.
- (3) The drive machinery and primary control apparatus must be installed in a facility which can prevent access by unauthorized personnel. The access door must have a sign which states that entry is restricted to authorized personnel.

WAC 296-59-135 Appendix 1 — Nonmandatory alternative lock-out procedure for ski lifts and tows.

- (1) To ensure the safety of all personnel engaged in lift maintenance activities, we insist that the following procedure be strictly adhered to.
 - (a) Criteria.
 - (i) Equipment must be deactivated and locked or tagged out before an employee is placed in a position where there is a hazard created by exposure to the components of ski lift or tows, equipment and/or systems.
 - (ii) This procedure relies on positive communication to indicate when lock-out safety is ensured. At any time this crew is working at a location remote from the control station, this procedure must be used by only one work crew whose members are working in close proximity to one another.
 - (iii) The operator and all potentially exposed employees must have a positive means of communication at all times. If anyone loses the communication means, it must be restored before exposure can occur or lock-out or tag-out can be broken.
 - (iv) Other radio transmissions breaking in or overriding the communications between control operator and remote work crew, if not controlled, can be a problem. There are considerations that should be followed:
 - (A) The first preferred method is to provide an isolated radio channel for communications between operator and remote work crew.
 - (B) If an isolated radio frequency is not possible, the entire area crew should be trained to recognize the radio conversation characteristics of this type of work to be notified when the work is in progress and be required to restrict use of their radios.
 - (v) All personnel working under this procedure must be thoroughly trained in the specific procedures to be followed and their individual requirements. The ski lift or tow controls must be under control of a fully qualified operator at all times.
 - (vi) Signs must be posted in motor rooms on the control panel or the master disconnect stating “men working on lifts.”
 - (vii) The control operator must not leave the close proximity of the control station unless the master disconnect is thrown to the off position and padlocked.
 - (viii) The “standby drive” must be locked out of service in such a manner that precludes the operation of the lift by jumping ignition, throwing a clutch, or hooking up a coupling, etc., whenever work is being performed on the equipment or system.
 - (ix) Methods for securing “standby drive” may be, but are not limited to the following:

- (A) Removal to secure a location or locking up “standby” drive coupling chain, belts, etc.;
- (B) Denying access to the standby motor by locking motor room door.
- (x) When the crew is working at either terminal in proximity of bullwheels, shafts, guideage, gears, belts, chains, etc., the master disconnect must be thrown to the off position and padlocked.
- (b) Work chair.
 - (i) Prior to crew loading on work chair, controls and communications must be thoroughly checked to confirm that they are in good working condition.
 - (ii) The operator and work crew must discuss and determine the safe speed for that particular lift. At no time must the work chair travel around either terminal bullwheel except at a very slow speed.
 - (iii) Employees riding in the work chair must face the direction of travel when chair is in motion.
 - (iv) Employees in work chair must pay special attention to ensure that equipment or tools, etc., will not be entangled on towers, ramps, or terminals as work chair passes by.
 - (v) Safety belts are required and there is a designated device on each work chair to hook onto. At no time will it be allowed to hook onto the tower or tower equipment while in the work chair, or hook onto a moving part of the lift if standing on the tower.
- (c) Operator and controls.
 - (i) Manual reset stop switches are required on all lifts. The operator must check and confirm that the lift cannot be started from any control location when the stop switch is depressed. The operator will leave the stop switch depressed until remote crew directs that they are ready to move.
 - (ii) Communications between operator and remote work crew will be on name basis. This is especially important if there are other radio communications or other crews working on other lifts.
- (2) Summation.
 - (a) If all these rules are adhered to, the operator can use the control circuit stop switch for repetitive type maintenance on towers. If the remote crew is to be at the location for some time, it is recommended that the operator throw the master disconnect switch to the off position and padlock it.
 - (b) A padlock on the disconnect switch is required when anybody is working on either terminal.

WAC 296-59-001 Foreword.

[Statutory Authority: RCW 49.17.010, .040, .050, and .060. 17-16-132 (Order 15-20), § 296-59-001, filed 08/01/2017, effective 09/01/2017. Statutory Authority: RCW 49.17.010, 49.17.040, 49.17.050, 49.17.060. 07-03-163, § 296-59-001, filed 1/24/07, effective 4/1/07. Statutory Authority: RCW 49.17.010, [49.17].040, and[49.17].050 . 01-11-038, § 296-59-001, filed 5/9/01, effective 9/1/01. Statutory Authority: Chapter 49.17 RCW. 88-14-108 (Order 88-11), § 296-59-001, filed 7/6/88.]

WAC 296-59-003 Scope and application.

[Statutory Authority: RCW 49.17.010, .040, .050, and .060. 17-16-132 (Order 15-20), § 296-59-003, filed 08/01/2017, effective 09/01/2017. Statutory Authority: RCW 49.17.010, 49.17.040, 49.17.050, 49.17.060. 07-03-163, § 296-59-003, filed 1/24/07, effective 4/1/07. Statutory Authority: Chapter 49.17 RCW. 88-14-108 (Order 88-11), § 296-59-003, filed 7/6/88.]

WAC 296-59-005 Incorporation of other standards.

[Statutory Authority: RCW 49.17.010, .040, .050, and .060. 17-16-132 (Order 15-20), § 296-59-005, filed 08/01/2017, effective 09/01/2017. Statutory Authority: RCW 49.17.010, 49.17.040, 49.17.050, 49.17.060. 06-19-074, § 296-59-005, filed 9/19/06, effective 12/1/06. Statutory Authority: RCW 49.17.010, [49.17].040, and [49.17].050. 01-11-038, § 296-59-005, filed 5/9/01, effective 9/1/01. Statutory Authority: Chapter 49.17 RCW. 94-16-145, § 296-59-005, filed 8/3/94, effective 9/12/94; 89-11-035 (Order 89-03), § 296-59-005, filed 5/15/89, effective 6/30/89; 88-14-108 (Order 88-11), § 296-59-005, filed 7/6/88.]

WAC 296-59-007 Definitions.

[Statutory Authority: RCW 49.17.010, .040, .050, and .060. 17-16-132 (Order 15-20), § 296-59-007, filed 08/01/2017, effective 09/01/2017. Statutory Authority: RCW 49.17.010, .040, .050, and .060. 06-19-074 (Order 05-42), § 296-59-007, filed 09/19/06, effective 12/01/06. Statutory Authority: Chapter 49.17 RCW. 88-14-108 (Order 88-11), § 296-59-007, filed 7/6/88.]

WAC 296-59-010 Safe place standards.

[Statutory Authority: RCW 49.17.010, .040, .050, and .060. 17-16-132 (Order 15-20), § 296-59-010, filed 08/01/2017, effective 09/01/2017. Statutory Authority: RCW 49.17.010, 49.17.040, 49.17.050, 01-11-038, § 296-59-010, filed 5/9/01, effective 9/1/01. Statutory Authority: Chapter 49.17 RCW. 88-14-108 (Order 88-11), § 296-59-010, filed 7/6/88.]

WAC 296-59-015 General requirements.

[Statutory Authority: RCW 49.17.010, .040, .050, and .060. 17-16-132 (Order 15-20), § 296-59-015, filed 08/01/2017, effective 09/01/2017. Statutory Authority: RCW 49.17.010, 49.17.040, 49.17.050, 49.17.060. 06-19-074, § 296-59-015, filed 9/19/06, effective 12/1/06. Statutory Authority: Chapter 49.17 RCW. 88-14-108 (Order 88-11), § 296-59-015, filed 7/6/88.]

WAC 296-59-020 Management's responsibility.

[Statutory Authority: RCW 49.17.010, .040, .050, and .060. 17-16-132 (Order 15-20), § 296-59-020, filed 08/01/2017, effective 09/01/2017. Statutory Authority: RCW 49.17.010, [49.17].040, and[49.17].050 . 01-11-038, § 296-59-020, filed 5/9/01, effective 9/1/01. Statutory Authority: Chapter 49.17 RCW. 88-14-108 (Order 88-11), § 296-59-020, filed 7/6/88.]

WAC 296-59-025 Employee's responsibility.

[Statutory Authority: RCW 49.17.010, .040, .050, and .060. 17-16-132 (Order 15-20), § 296-59-025, filed 08/01/2017, effective 09/01/2017. Statutory Authority: RCW 49.17.010, [49.17].040, and[49.17].050 . 01-11-038, § 296-59-025, filed 5/9/01, effective 9/1/01. Statutory Authority: Chapter 49.17 RCW. 88-14-108 (Order 88-11), § 296-59-025, filed 7/6/88.]

WAC 296-59-027 Work activities which include skiing.

[Statutory Authority: RCW 49.17.010, .040, .050, and .060. 17-16-132 (Order 15-20), § 296-59-027, filed 08/01/2017, effective 09/01/2017. Statutory Authority: Chapter 49.17 RCW. 88-14-108 (Order 88-11), § 296-59-027, filed 7/6/88.]

WAC 296-59-030 Safety bulletin board.

[Statutory Authority: RCW 49.17.010, .040, .050, and .060. 17-16-132 (Order 15-20), § 296-59-030, filed 08/01/2017, effective 09/01/2017. Statutory Authority: RCW 49.17.010, [49.17].040, and[49.17].050 . 01-11-038, § 296-59-030, filed 5/9/01, effective 9/1/01. Statutory Authority: Chapter 49.17 RCW. 88-14-108 (Order 88-11), § 296-59-030, filed 7/6/88.]

WAC 296-59-035 First aid.

[Statutory Authority: RCW 49.17.010, 49.17.040, and 49.17.050. 01-11-038, § 296-59-035, filed 5/9/01, effective 9/1/01; 00-01-038, § 296-59-035, filed 12/7/99, effective 2/1/00. Statutory Authority: Chapter 49.17 RCW. 88-14-108 (Order 88-11), § 296-59-035, filed 7/6/88.]

WAC 296-59-050 Personal protective equipment, general requirements.

[[Statutory Authority: RCW 49.17.010, .040, .050, and .060. 20-12-091 (Order 19-05) § 29659-050, filed 06/02/2020, effective 10/01/2020. Statutory Authority: RCW 49.17.010, .040, .050, and .060. 17-16-132 (Order 15-20), § 296-59-050, filed 08/01/2017, effective 09/01/2017. Statutory Authority: RCW 49.17.010, 49.17.040, 49.17.050, 49.17.060. 09-05-071, § 296-59-050, filed 2/17/09, effective 4/1/09. Statutory Authority: RCW 49.17.010, [49.17].040, and[49.17].050 . 01-11-038, § 296-59-050, filed 5/9/01, effective 9/1/01. Statutory Authority: Chapter 49.17 RCW. 88-14-108 (Order 88-11), § 296-59-050, filed 7/6/88.]

WAC 296-59-055 Lockout requirements.

[Statutory Authority: RCW 49.17.010, .040, .050, and .060. 17-16-132 (Order 15-20), § 296-59-055, filed 08/01/2017, effective 09/01/2017. Statutory Authority: Chapter 49.17 RCW. 88-14-108 (Order 88-11), § 296-59-055, filed 7/6/88.]

WAC 296-59-060 Vessel or confined area requirements.

[Statutory Authority: RCW 49.17.010, .040, .050, and .060. 18-04-096 (Order 17-26), § 296-59-060, filed 02/06/2018, effective 03/09/2018. Statutory Authority: RCW 49.17.010, .040, .050, and .060. 17-16-132 (Order 15-20), § 296-59-060, filed 08/01/2017, effective 09/01/2017. Statutory Authority: Chapter 49.17 RCW. 95-04-007, § 296-59-060, filed 1/18/95, effective 3/1/95; 88-14-108 (Order 88-11), § 296-59-060, filed 7/6/88.]

WAC 296-59-065 Fire protection and ignition sources.

[Statutory Authority: RCW 49.17.010, .040, .050, and .060. 17-16-132 (Order 15-20), § 296-59-065, filed 08/01/2017, effective 09/01/2017. Statutory Authority: RCW 49.17.010, [49.17].040, and[49.17].050 . 01-11-038, § 296-59-065, filed 5/9/01, effective 9/1/01. Statutory Authority: Chapter 49.17 RCW. 88-14-108 (Order 88-11), § 296-59-065, filed 7/6/88.]

WAC 296-59-070 Illumination.

[Statutory Authority: RCW 49.17.010, .040, .050, and .060. 17-16-132 (Order 15-20), § 296-59-070, filed 08/01/2017, effective 09/01/2017. Statutory Authority: RCW 49.17.010, [49.17].040, and[49.17].050 . 01-11-038, § 296-59-070, filed 5/9/01, effective 9/1/01. Statutory Authority: Chapter 49.17 RCW. 88-14-108 (Order 88-11), § 296-59-070, filed 7/6/88.]

WAC 296-59-075 Electrical equipment and distribution.

[Statutory Authority: RCW 49.17.010, .040, .050, and .060. 17-16-132 (Order 15-20), § 296-59-075, filed 08/01/2017, effective 09/01/2017. Statutory Authority: Chapter 49.17 RCW. 88-14-108 (Order 88-11), § 296-59-075, filed 7/6/88.]

WAC 296-59-080 Installation, inspection, and maintenance of pipes, piping systems, and hoses.

[Statutory Authority: RCW 49.17.010, .040, .050, and .060. 17-16-132 (Order 15-20), § 296-59-080, filed 08/01/2017, effective 09/01/2017. Statutory Authority: Chapter 49.17 RCW. 88-14-108 (Order 88-11), § 296-59-080, filed 7/6/88.]

WAC 296-59-085 Scaffolds, construction, use, and maintenance.

[Statutory Authority: RCW 49.17.010, .040, .050, and .060. 17-16-132 (Order 15-20), § 296-59-085, filed 08/01/2017, effective 09/01/2017. Statutory Authority: RCW 49.17.010, [49.17].040, and[49.17].050 . 01-11-038, § 296-59-085, filed 5/9/01, effective 9/1/01. Statutory Authority: Chapter 49.17 RCW. 88-14-108 (Order 88-11), § 296-59-085, filed 7/6/88.]

WAC 296-59-090 Mobile equipment and lift trucks.

[Statutory Authority: RCW 49.17.010, .040, .050, and .060. 17-16-132 (Order 15-20), § 296-59-090, filed 08/01/2017, effective 09/01/2017. Statutory Authority: RCW 49.17.010, 49.17.040, 49.17.050, and 49.17.060. 03-11-060, § 296-59-090, filed 5/19/03, effective 8/1/03. Statutory Authority: Chapter 49.17 RCW. 88-14-108 (Order 88-11), § 296-59-090, filed 7/6/88.]

WAC 296-59-095 Requirements for cranes and hoists — General safety and health standards to prevail.

[Statutory Authority: Chapter 49.17 RCW. 88-14-108 (Order 88-11), § 296-59-095, filed 7/6/88.]

WAC 296-59-115 Ski lift facilities and structures.

[Statutory Authority: RCW 49.17.010, .040, .050, and .060. 20-12-091 (Order 19-05) § 296-59-115, filed 06/02/2020, effective 10/01/2020. Statutory Authority: RCW 49.17.010, .040, .050, and .060. 17-16-132 (Order 15-20), § 296-59-115, filed 08/01/2017, effective 09/01/2017. Statutory Authority: Chapter 49.17 RCW. 88-14-108 (Order 88-11), § 296-59-115, filed 7/6/88.]

WAC 296-59-120 Ski lift operations.

[Statutory Authority: RCW 49.17.010, .040, .050, and .060. 17-16-132 (Order 15-20), § 296-59-120, filed 08/01/2017, effective 09/01/2017. Statutory Authority: Chapter 49.17 RCW. 88-14-108 (Order 88-11), § 296-59-120, filed 7/6/88.]

WAC 296-59-125 Ski lift aerial work platforms.

[Statutory Authority: RCW 49.17.010, .040, .050, and .060. 20-12-091 (Order 19-05) § 296-59-125, filed 06/02/2020, effective 10/01/2020. Statutory Authority: RCW 49.17.010, .040, .050, and .060. 18-04-096 (Order 17-26), § 296-59-125, filed 02/06/2018, effective 03/09/2018. Statutory Authority: RCW 49.17.010, .040, .050, and .060. 17-16-132 (Order 15-20), § 296-59-125, filed 08/01/2017, effective 09/01/2017. Statutory Authority: Chapter 49.17 RCW. 88-14-108 (Order 88-11), § 296-59-125, filed 7/6/88.]

WAC 296-59-130 Ski lift machinery guarding.

[Statutory Authority: RCW 49.17.010, .040, .050, and .060. 17-16-132 (Order 15-20), § 296-59-130, filed 08/01/2017, effective 09/01/2017. Statutory Authority: RCW 49.17.010, 49.17.040, 49.17.050, and 49.17.060. 04-14-028, § 296-59-130, filed 6/29/04, effective 1/1/05. Statutory Authority: Chapter 49.17 RCW. 88-14-108 (Order 88-11), § 296-59-130, filed 7/6/88.]

WAC 296-59-135 Appendix I — Nonmandatory alternative lock-out procedure for ski lifts and tows.

[Statutory Authority: RCW 49.17.010, .040, .050, and .060. 17-16-132 (Order 15-20), § 296-59-135, filed 08/01/2017, effective 09/01/2017. Statutory Authority: Chapter 49.17 RCW. 88-23-054 (Order 88-25), § 296-59-135, filed 11/14/88.]